

Manufacturers of High-Quality Farm Machinery

Parts Catalogue



Xcel 1250

(Valid from serial no. 1094 onwards)

Parts are subject to change at any time, without prior or direct notice to the customer. The contents of this manual can as well be changed without prior notice. For information about parts, which are not mentioned in this manual, you are advised to consult the technical support of your supplier.

This manual has been made with all possible effort, but Hi-Spec Engineering and its suppliers cannot be responsible for possible mistakes in this manual, nor for the consequences.

Hi-Spec Xcel 1250

This parts book is **only relevant to machines with the information provided on the front cover onward**. If machine does not fall within this range please refer to previous parts books due to changes made at this time.

List of changes from previous XCEL model:

THIS PARTS BOOK

2 FLOOR CHAINS

SINGLE FLOOR BOX

520 RPM WIDER REAR GEARBOX

1100MM DIA REAR DISCS

BEATER ROTOR DRIVEN FROM REAR

PREVIOUS PARTS BOOK

4 FLOOR CHAINS

2 FLOOR BOXES

420 RPM NARROW REAR GEARBOX

960MM DIA REAR DISCS

SEPARATE BEATER GEARBOX

Please check that the specification above is relevant to your parts order.

When ordering parts:

- Quote Machine Serial Number and Model.
- Quote the complete Part Number and Description.
- Where reference is made to Left and Right, this should be understood to mean left or right when the machine is viewed from the rear.

Safety first:

Use only genuine Hi-Spec spare parts for this machine. Use of spare parts not supplied or recommended by Hi-Spec could result in injury, to the operator or damage to the machine, and invalidate the warranty

NOTE:

- The illustrations in this book are for identification purposes only.
- Hi-Spec Engineering reserves the right to make changes or improvements at any time without incurring any obligation to make such changes on products sold previously.

Contents

Layout of the Xcel 1250.....	4
Hydraulic sprung drawbar.....	6
Weighing System.....	7
Air Brakes.....	9
Floor Chain System.....	10
Hydraulic Fittings & Attachments.....	12
Hydraulic Fittings & Attachments.....	13
Rotor Drive System.....	14
Rotor & Rear beaters.....	16
Lights and light Fittings.....	18
Fittings.....	19
Drawbar fittings.....	20
Chain covers & hood fittings.....	21
Chain oiler.....	22
Rubbers.....	23
Spreading Disc and Vane Complete.....	24
Decals.....	26
Floor chain drive gearbox.....	27
Rear spreading spinners gearbox.....	28
PTO Shafts.....	29
Drive shafts and Carrier Bearings.....	33
Drive shaft covers.....	35
Axles.....	37
Wheel & Tyre Assembly.....	38
Sales and Service.....	39

Layout of the Xcel 1250



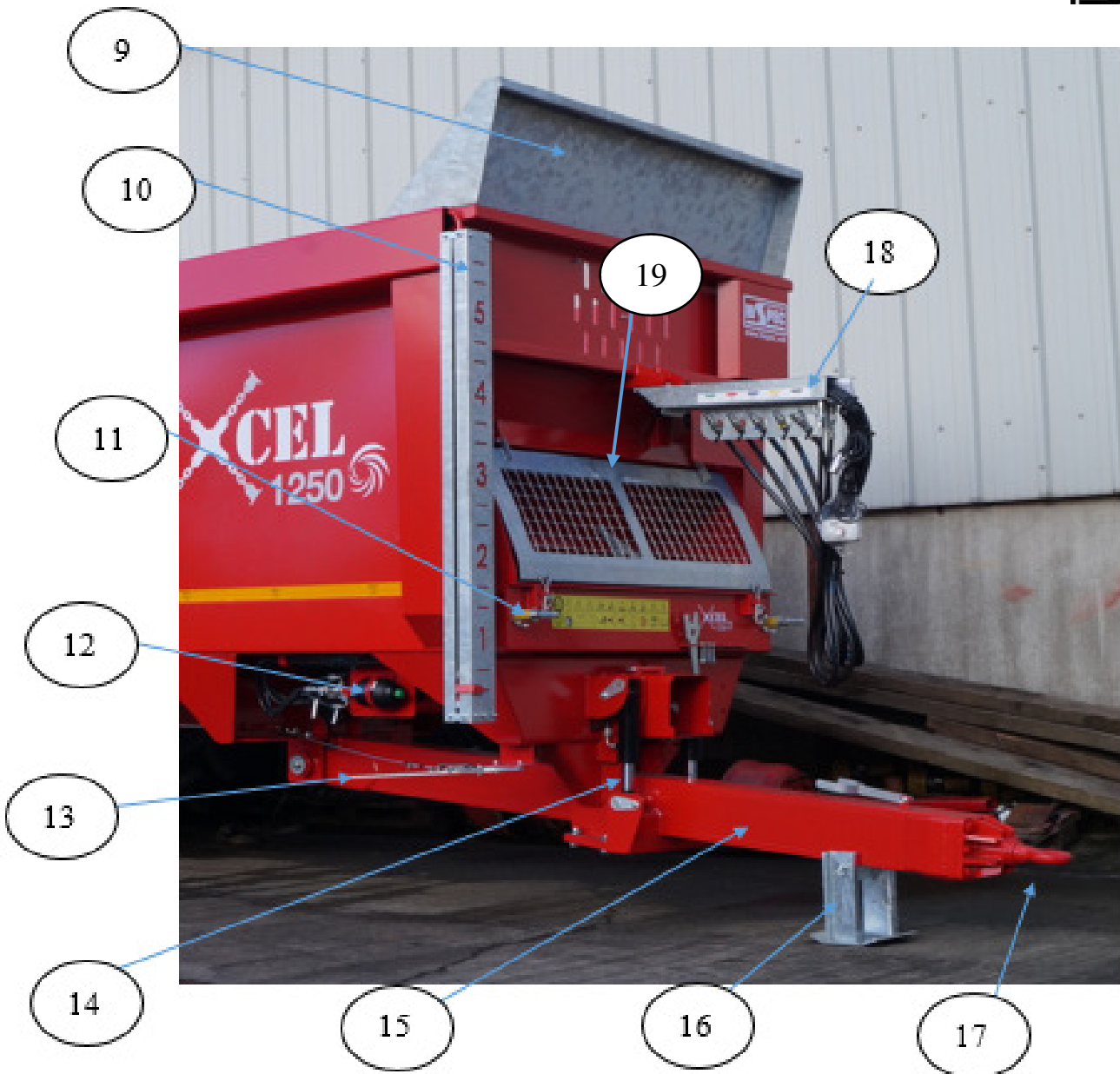

Reference	Part no.	Description
1	DS/0195	Slurry door
2	DS/0150	Light cover (see page 18)
3	DS/0154	Galvanized mudguards (see page 19)
4	DS/0103	Floor chain gearbox (see page 28)
5	DS/0196	Adjustable hood flap (see page 25)
6		Discs and spreading vanes (see page 24,25,26)
7	DS/0183	Rear Hood
8	DS/0165	Rear hood lift hook (see page 21)
9	DS/0156	Spill guard (see page 19)
10	DS/0043	Door height indicator
11		Floor chain tensioner (see page 10)
12	TR/0022	Accumulator for sprung drawbar (see page 6)
13	MM/3601	Handbrake
14		Hydraulic sprung drawbar (see page 6)
15	DS/0162	Drawbar (see page 20)
16	DS/0159	Stand (see page 20)
17	MM/9210	Swivel hitch (see page 20)
18	DS/0197	Hydraulic fittings holder
19	DS/0086	Front grill

Hydraulic sprung drawbar

	Part no.	Description
1	TR/0005	Hydraulic ram
2	DS/0186	Pin 30mm x 115mm
3	GP/1053 GP/1100 GP/1124	M20 x 60 bolt, nut & washer
4	GP/1015 GP/1097 GP/1121	M10 x 30 bolt nut & washer
5	GP/1023 GP/1098 GP/1122	M12 x 40 bolt nut & washer
6	DS/0136	Accumulator bracket
7	MM/H007	½ inch hydraulic hose
8	TR/0022	Accumulator bottle
9	DS/0187	Shut off valve

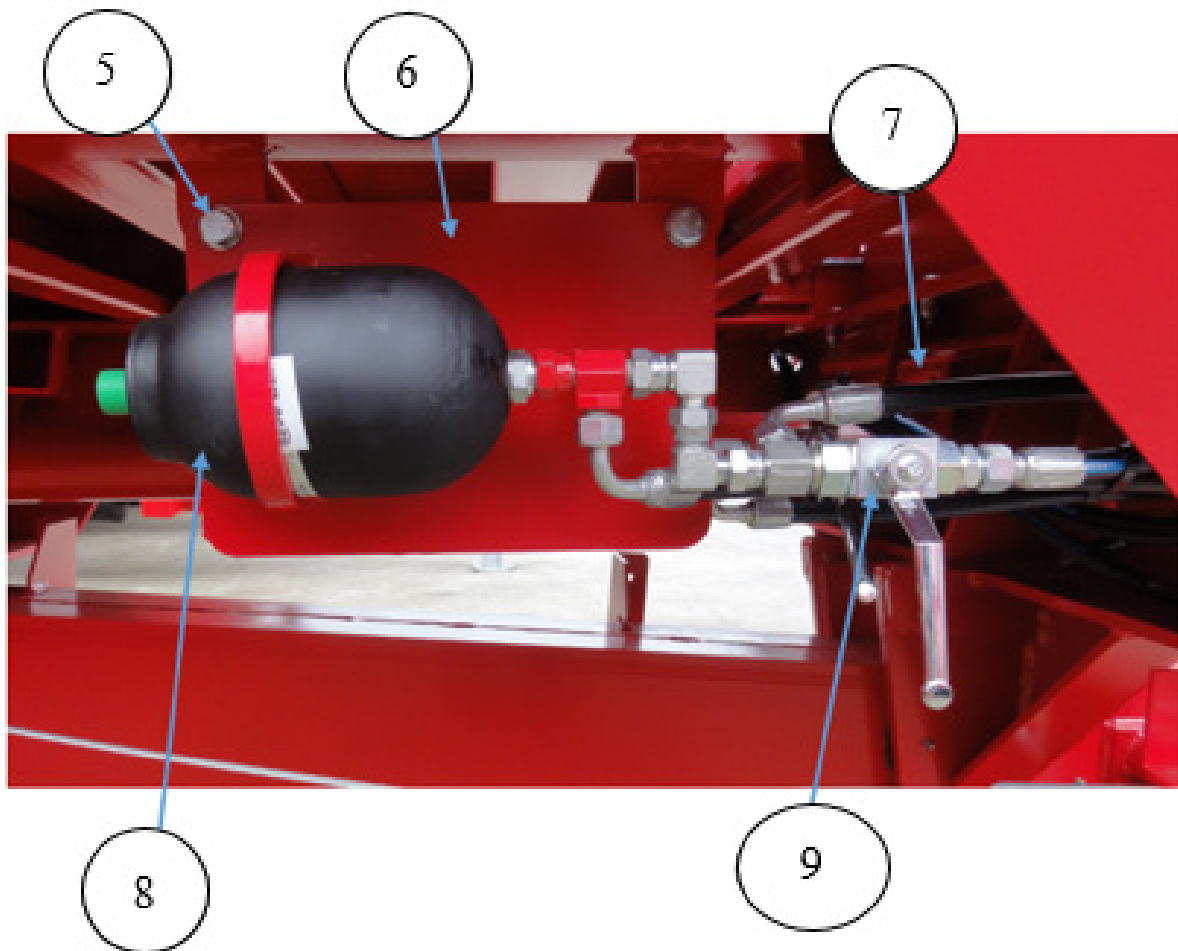
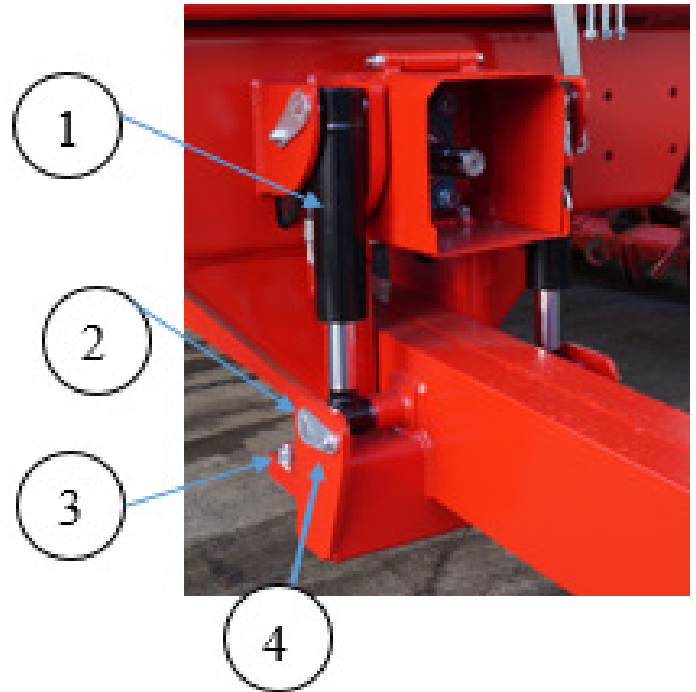

Weighing System

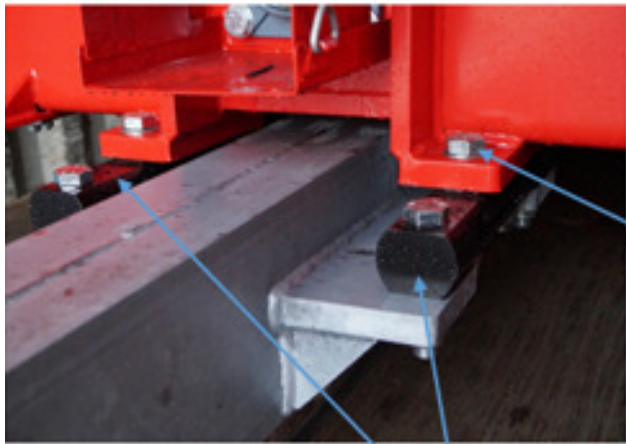

1

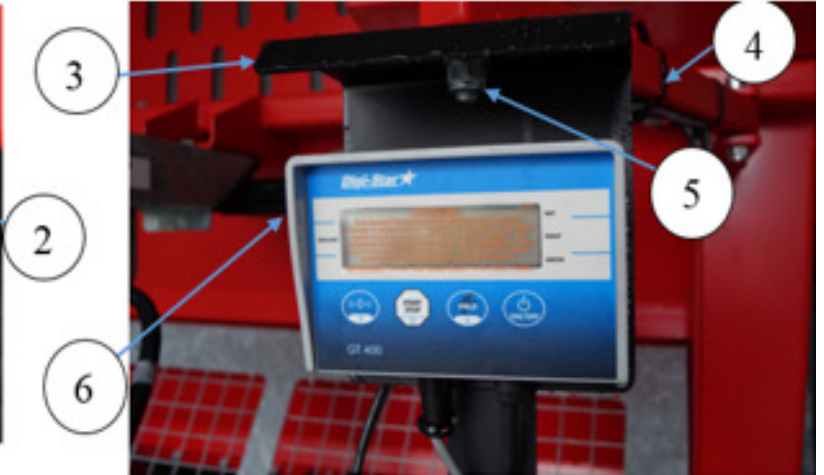

3

2

6

4

5



7

8

9



10

	Part no.	Description
1	DS/0106	Front weigh cell
2	GP/1067 GP/1101 GP/10931	M24 x 120 bolt, nut & washers
3	DS/0137	Bracket for digital readout
4	DS/0138	Bracket arm
5	GP/10753 GP/1102 GP/10932	M14 x 60 bolt nut & washer
6	DS/0104	Digi Star GT 400 digital readout
7	DS/0105	Axle weigh cell
8	GP/1067 GP/1101 GP/10931	M24 x 120 bolt, nut & washer
9	MM/5008	Weigh cell junction box
10	DS/0107	Power cable

Fully hydraulic stand

	Part no.	Description
1	DS/0187	Shut off valve
2	DS/0188	Stand

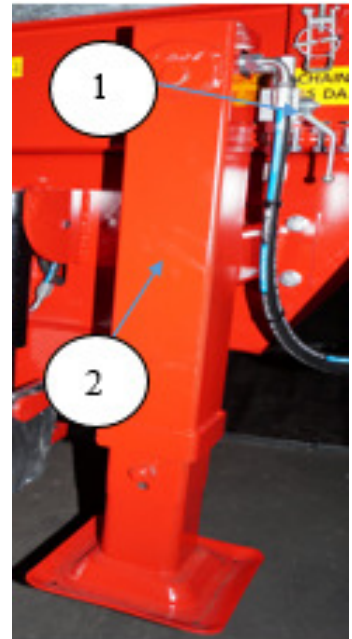

Standard Jack

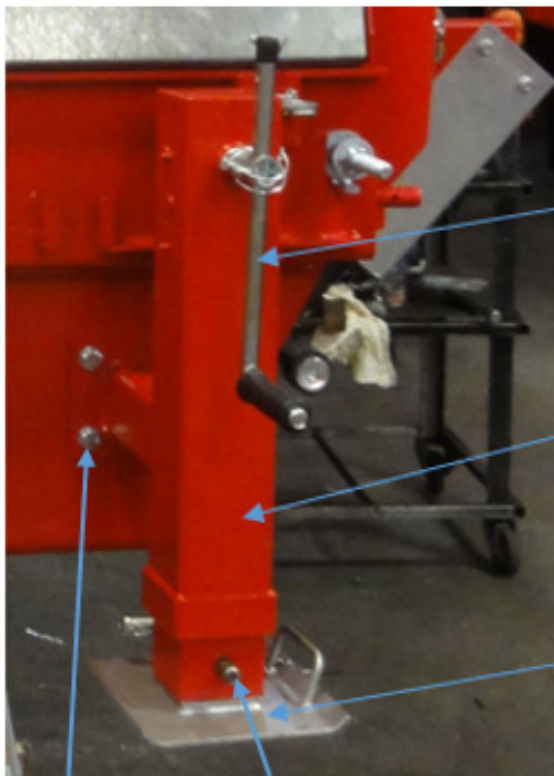

	Part no	Description
1	MM/6571	Handle
2	MM/657	Stand
3	DS/0194	Leg
4	DS/0160	Pin
5	GP/1108 GP/1103 GP/1148	M18 x 60 bolt nut & washer
	MM/658	Complete kit

Air Brakes

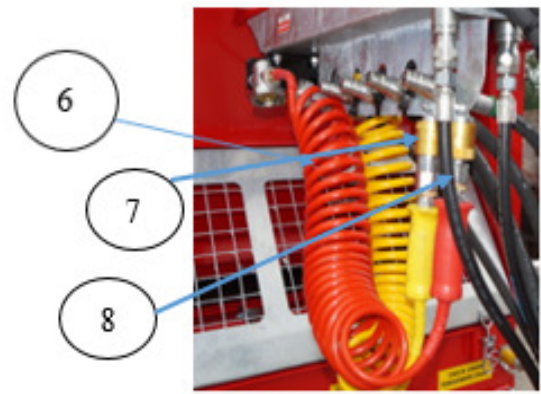
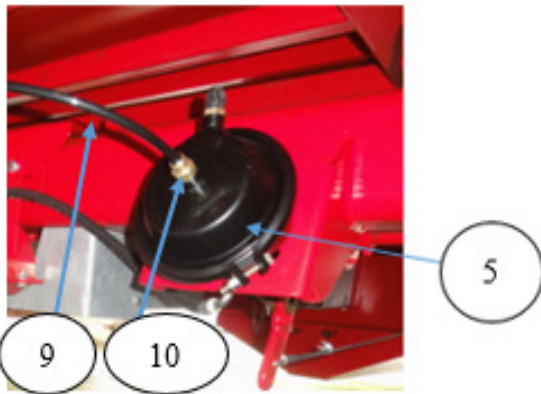
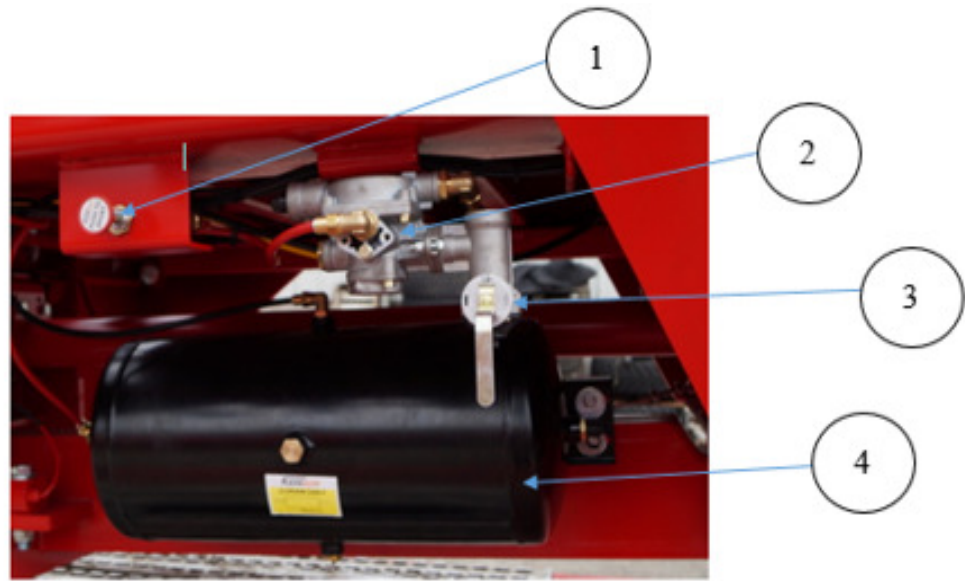

	Part No.	Description
1	AXL/0028	Push to shunt valve
2	DS/0189	Relay valve
3	DS/0190	Manual load proportioning valve
4	GP/00011	Air tank
5	AXL/1012	Brake chamber
6	GP/00008	Service line (yellow)
	GP/00007	Emergency line (red)
7	DS/0191	Female quick release coupling (c type)
8	DS/0192	Male quick release coupling (c type)
9	GP/00017	Black air tubing (state length)
10	DS/0193	Straight stud fitting
		Complete kit

Floor Chain System

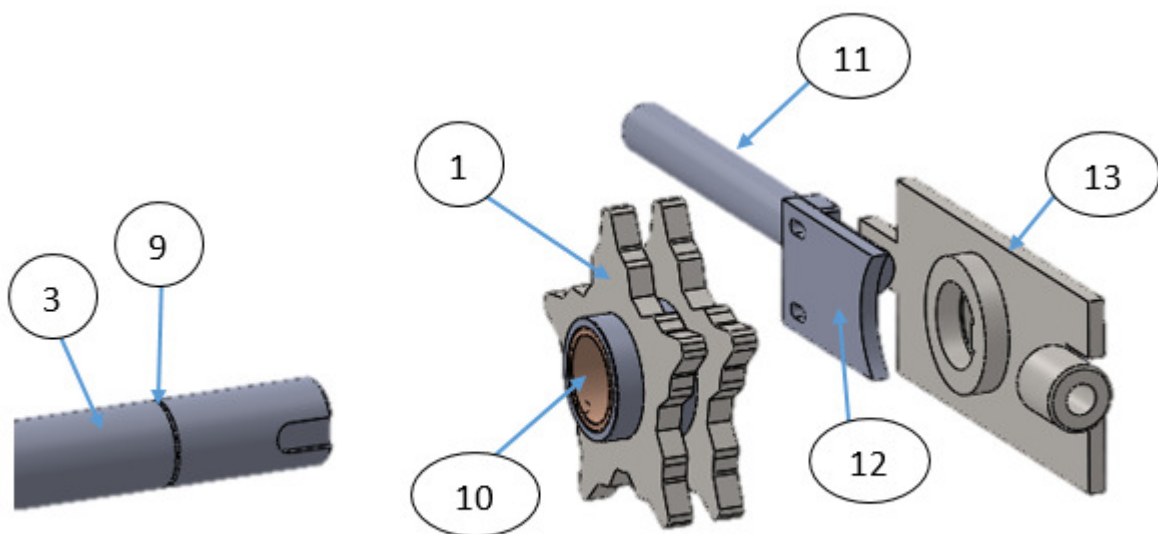
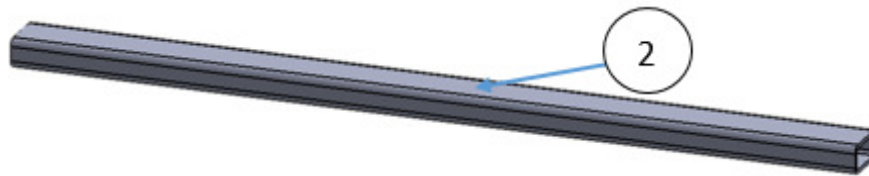
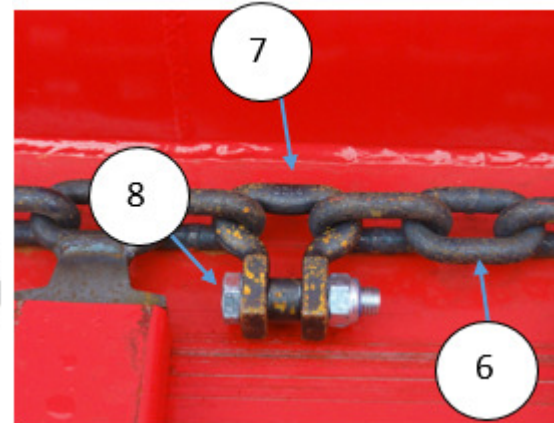
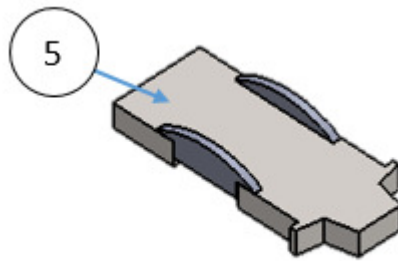
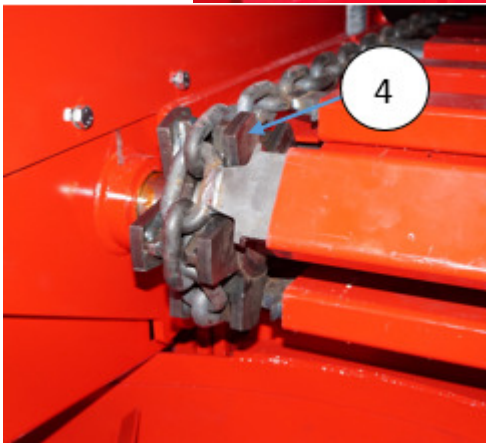
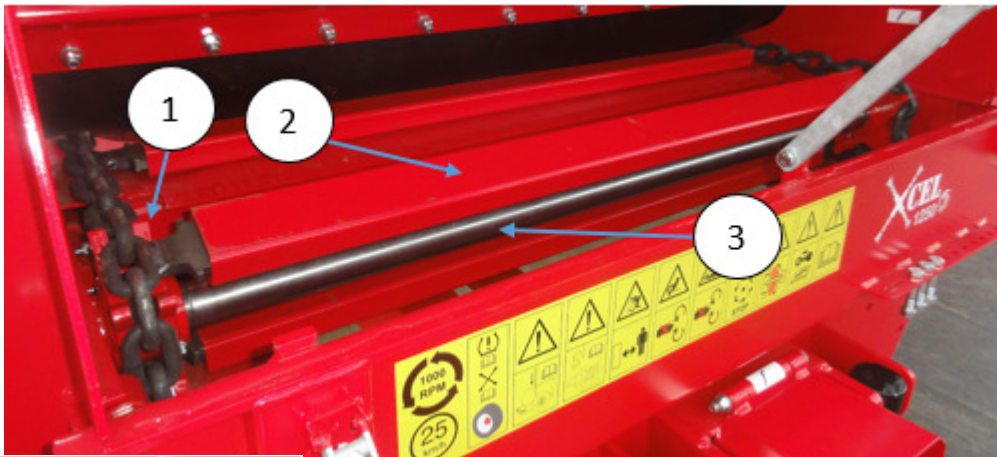

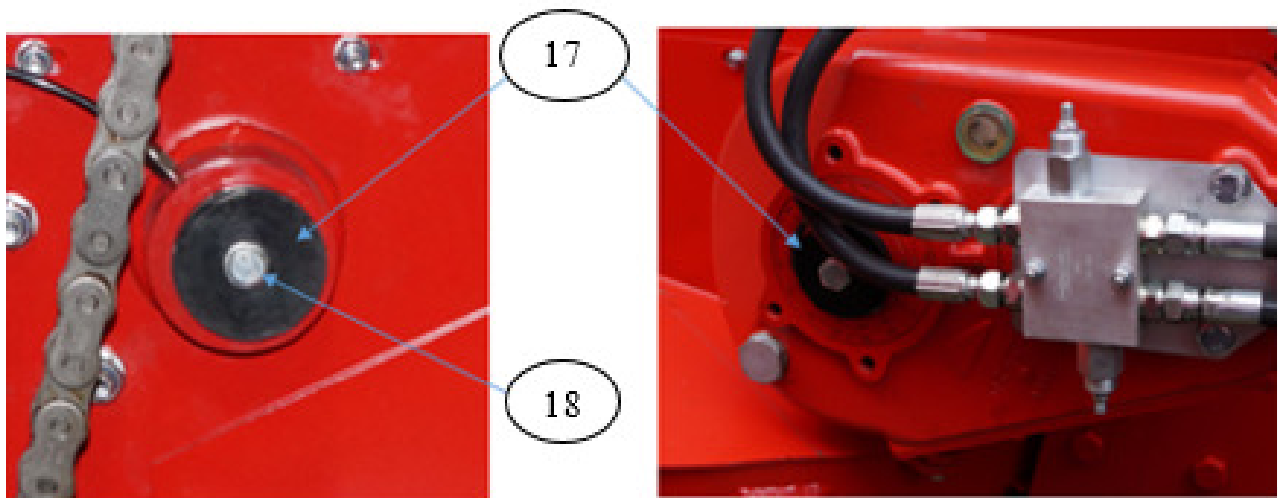
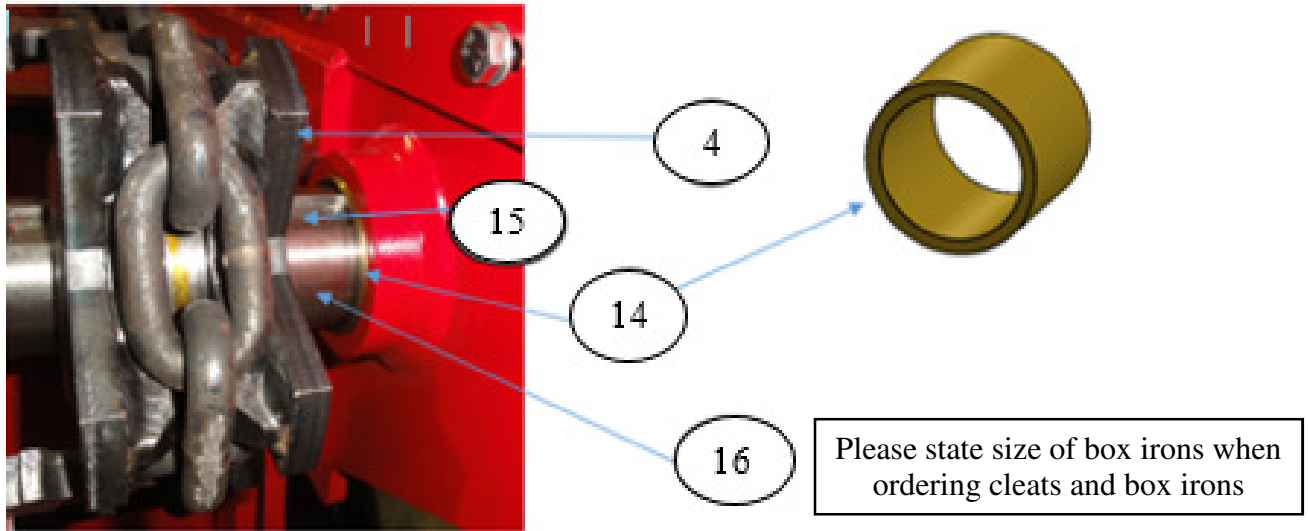

	Part No.	Description
1	DS/0083	Front floor chain idler sprockets
2	DS/00361	Floor cross section box 80mm x 40mm x 5
3	DS/0128	Front shaft
4	DS/0084	Rear floor chain drive sprocket
5	DS/0125	Cleat for 80 x 40 x 5
6	DS/0082	Floor chain
7	DS/0079	Chain joiner link
8	GP/1044 GP/1099	M16 x 70 bolt, nut and 16mm spacer
9	GP/3343	Circlip
10	DS/0139	Brass bushing for front idler sprocket
11	DS/0140	Tensioner guide
12	DS/0141	Cleaner scraper
13	DS/0142	Shaft housing
14	DS/0143	Brass bushing for rear shaft housing
15	DS/0144	Key (18 x 15 x 140)
16	DS/0080	Rear shaft with keyway
17	DS/0130	End cap for floor shaft
18	GP/1023 GP/1122	M12 x 40 bolt and washer

Hydraulic Fittings & Attachments

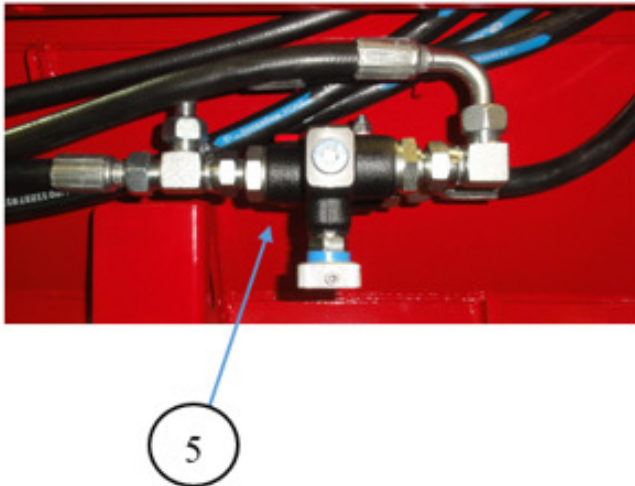
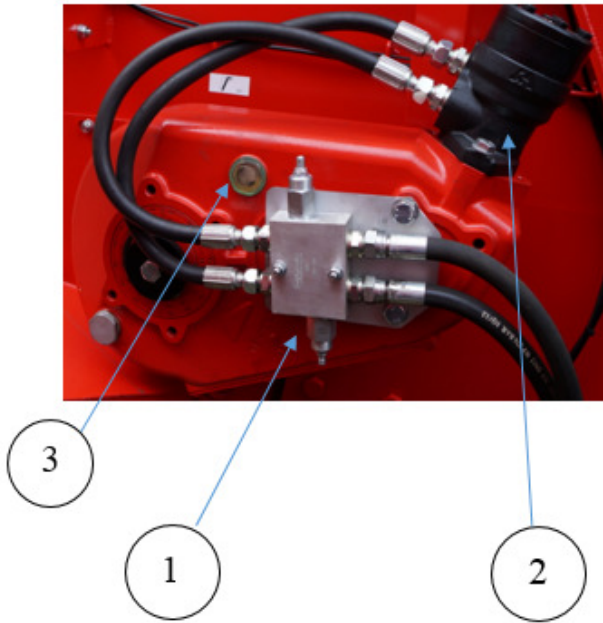

	Part No.	Description
1	DS/0015	Floor drive Cross line relief valve
2	DS/0024	Floor motor drive
3	DS/9175	Oil level indicator
4	DS/0100	Electronic floor speed control
5	DS/0146	Manual floor speed control
6	DS/0041	Electronic floor speed control box

Hydraulic Fittings & Attachments

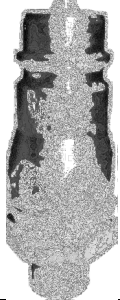
GP/2000	1/2" Quick release female	
GP/2002	Hydraulic fitting	
MM/H006 MM/H007	3/8" Hose 1/2" Hose When ordering hose please state length and end fittings required.	
DS/0039 DS/0040	HS98 Slurry door ram HS99 Slurry door ram	

Rotor Drive System

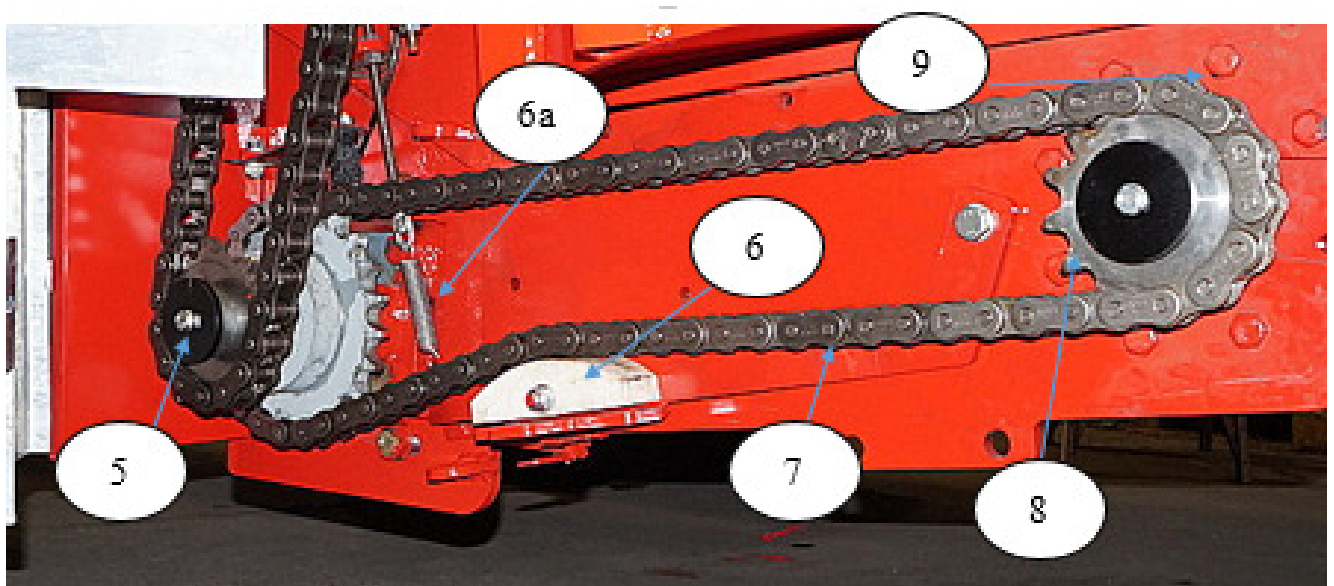
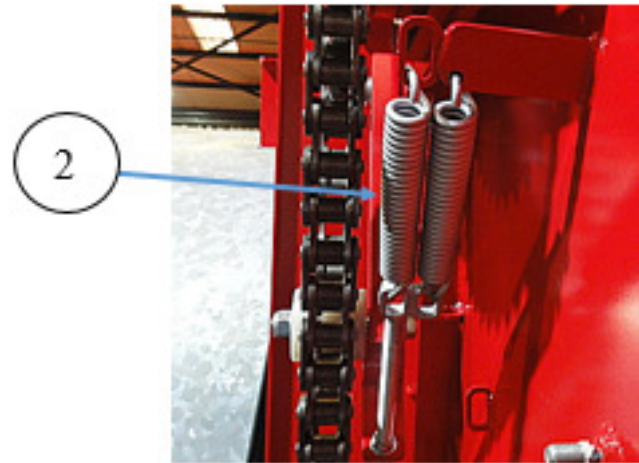
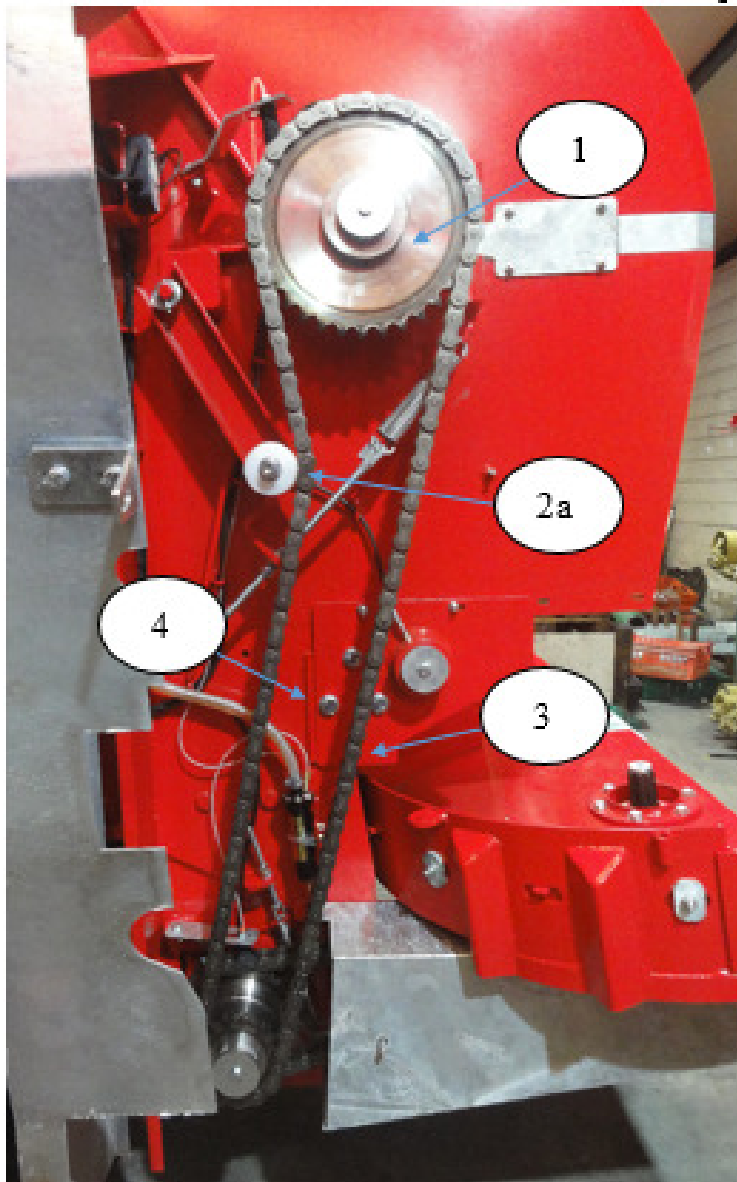

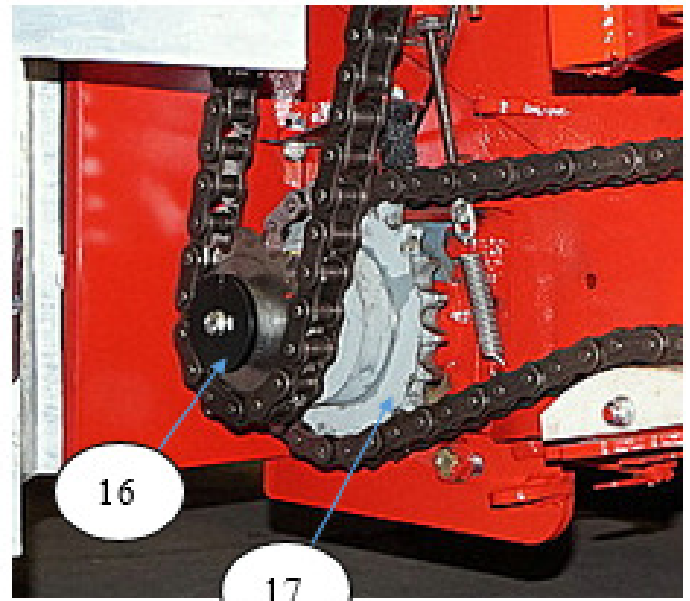
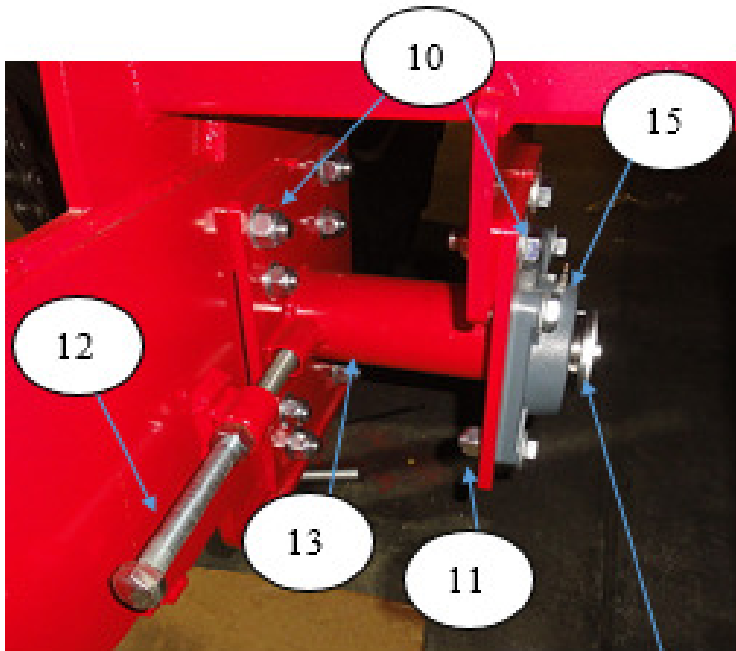

	Part No.	Description
1	SS/806	33 Tooth sprocket
2	DS/0124	Dual spring chain tensioner (individual spring)
2a	DS/0085	Nylon Chain tensioner
3	DS/0111	ASA 100H Drive chain
4	GP/1108 GP/1103 GP/1148	M18 x 60 bolt, nut & washer
5	GP/1023 GP/1122	M12 x 40 bolt and washer
6	DS/0070	Nylon Chain tensioner
6a	DS/0124	Single spring chain tensioner
7	DS/0110	ASA 100H drive chain
8	DS/0023	14 tooth sprocket
9	GP/10753 GP/1102 GP/10932	M14 x 60 bolt, nut & washer
10	GP/1053 GP/1100 GP/1124	M20 x 60 bolt nut & washer
11	GP/1108 GP/1103 GP/1148	M18 x 60 bolt nut & washer
12	GP/1104	Adjuster screw M20 threaded bar
13	DS/0147	Counter shaft housing
14	DS/0148	Rotor Drive Counter shaft 50mm
15	MM/0551	FX11 taper lock four bolt flange bearing
16	DS/0130	Shaft end plate (Same for all shafts)
17	DS/0112	22 tooth sprocket

Rotor & Rear beaters

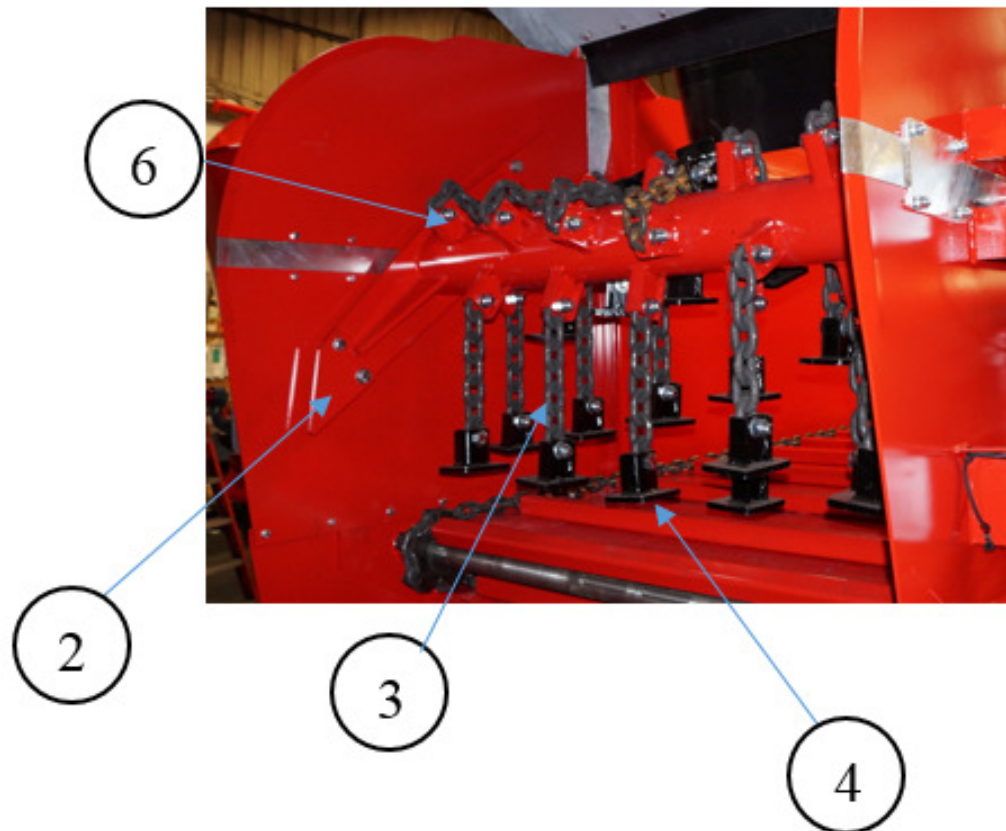
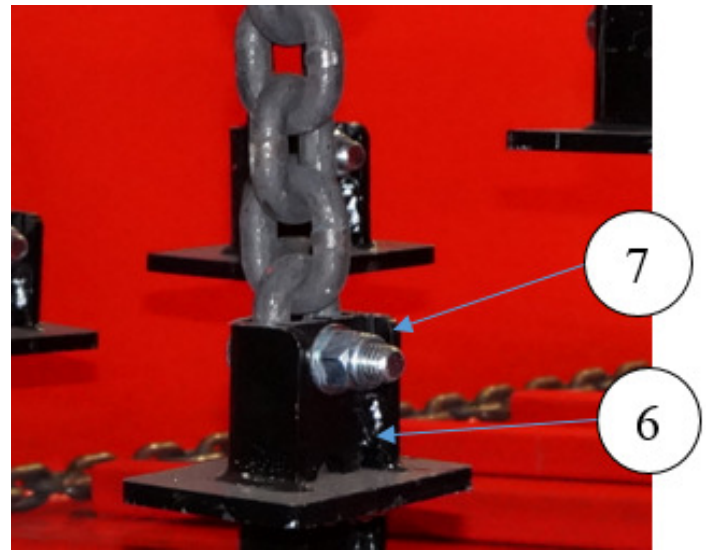
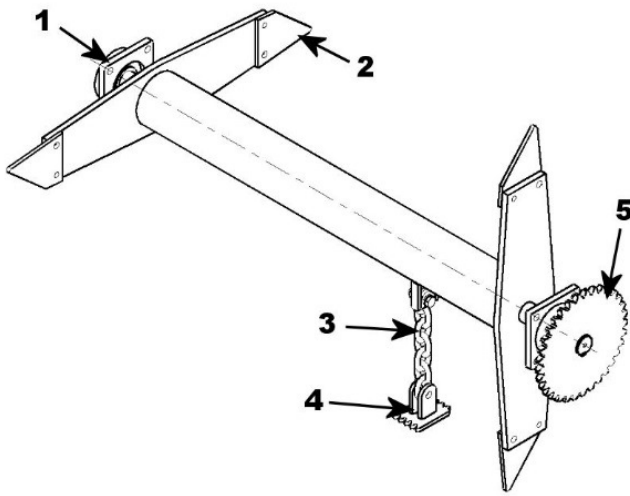

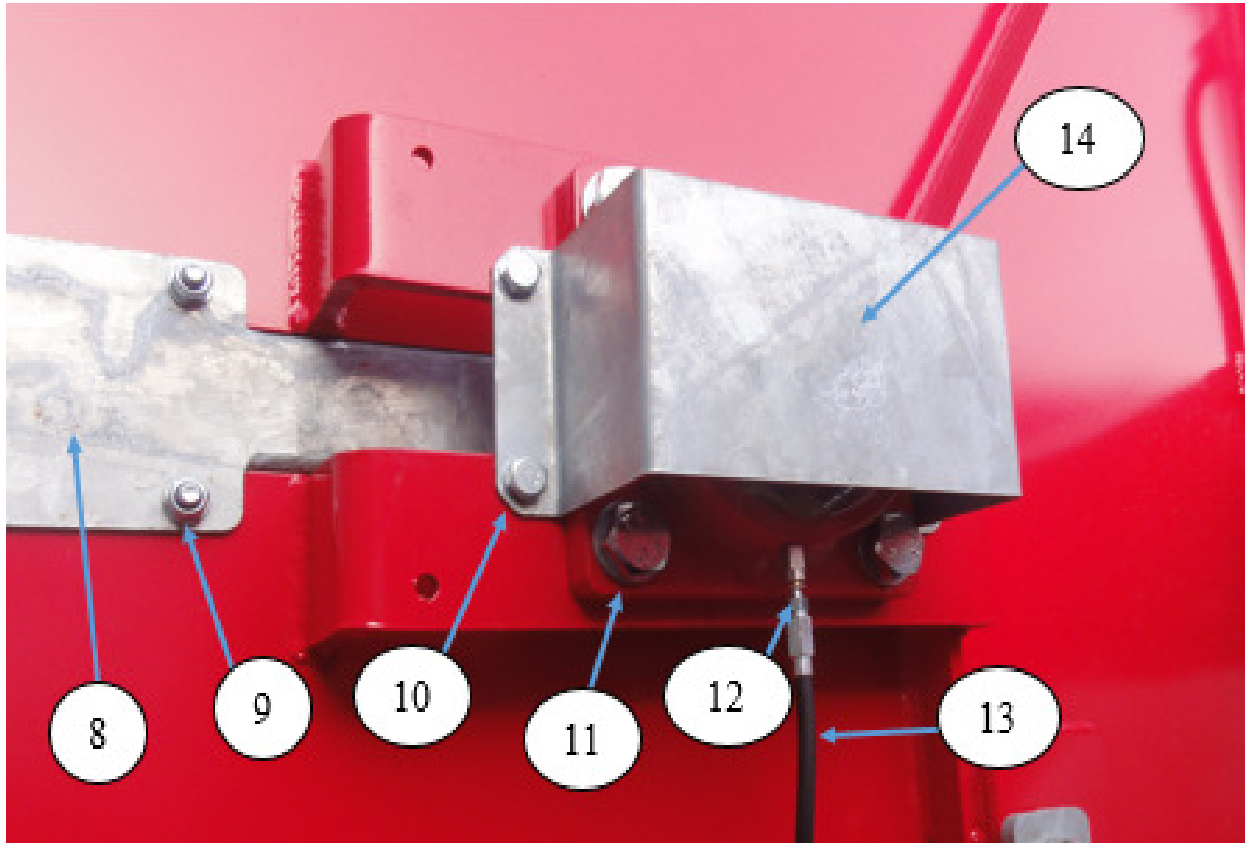

	Part No.	Description
1	MM/0502 MM/0503	UC312 Housing UC312 Insert
2	DS/0052	Rotor blade
3	DS/0075	Marine chain
4	DS/0032	Flail head
5	SS/806	33 Tooth Sprocket
6	DS/0075	Chain and flail complete
7	GP/1042 GP/1099 GP/1123	M16 x 50 bolt nut & washer
8	DS/0182	Rotor slot cover
9	GP/1016 GP/1097 GP/1121	M10 x 40 bolt, nut & washer
10	GP/1015 GP/1097 GP/1121	M10 x 30 bolt, nut & washer
11	GP/1053 GP/1100 GP/1124	M20 x 60 bolt, nut & washer
12	MM/M8ST	Grease fitting
13	MM/100001	Grease hose (state length when ordering)
14	DS/0149	Rotor bearing guard

Lights and light Fittings



	Part No.	Description
1	DS/0126	Bracket for light and light cover
2	DS/0150	Light cover
3	DS/0151	Light cover bushing
4	DS/0152	Light cover cap
5	DS/0153	Light cover rod
6	GP/0117	L.E.D side light
7	GP/0126	Hamburger L.E.D light
8	GP/0129	L.E.D mudguard light
9	GP/3503	7 pin plug

Fittings

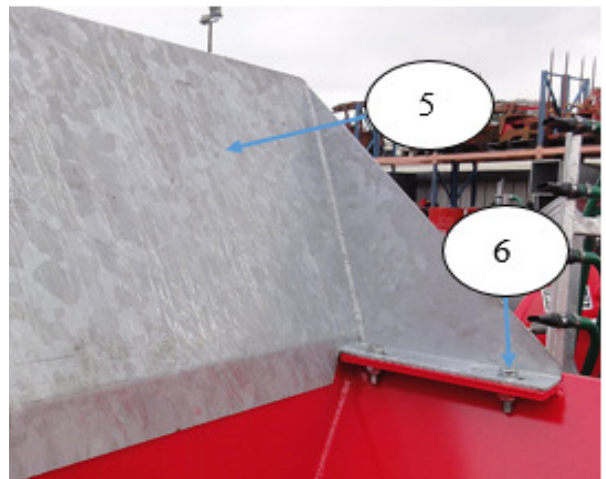
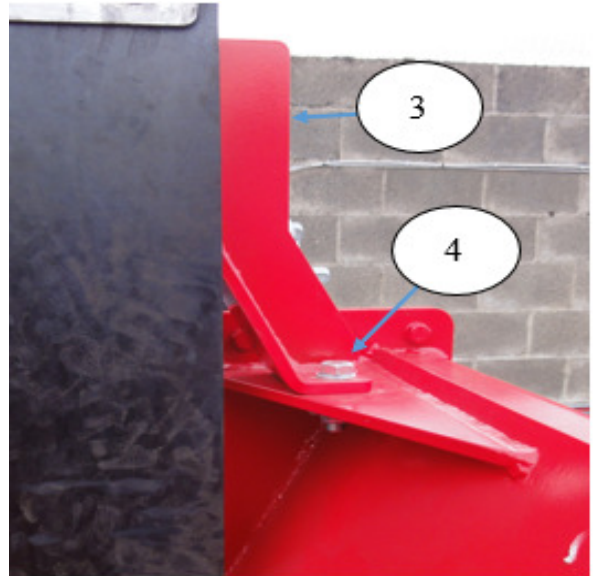
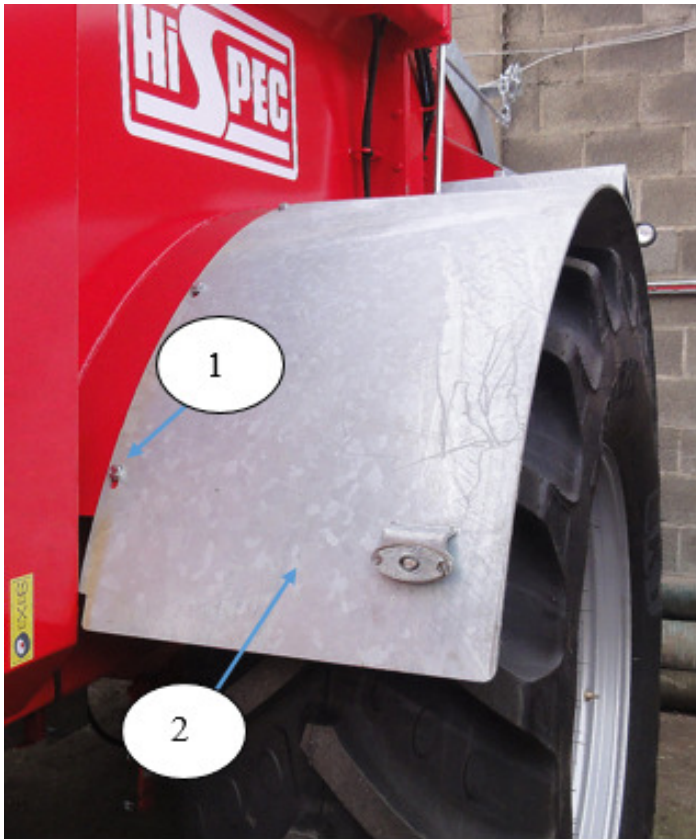

	Part No.	Description
1	GP/1023 GP/1098 GP/1122	M12 x 40 bolt, nut & washer
2	DS/0154	Mudguard (state tyre size)
3	DS/0155	Rear throwback flap mount
4	GP/10753 GP/1102 GP/10932	M14 x 60 bolt, nut & washer
5	DS/0156	Spill guard
6	GP/10753 GP/1102 GP/10932	M14 x 60 bolt, nut & washer
7	GP/1023 GP/1098 GP/1122	M12 x 40 bolt, nut & washer
8	DS/0157	Ladder
9	GP/1028 GP/1098 GP/1122	M12 x 80 bolt, nut & washer

Drawbar fittings

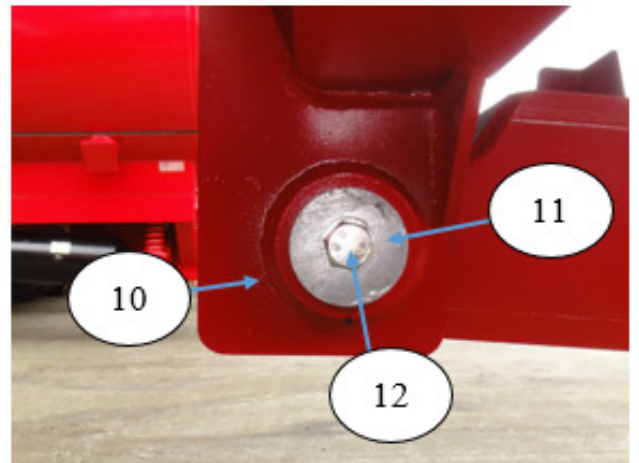
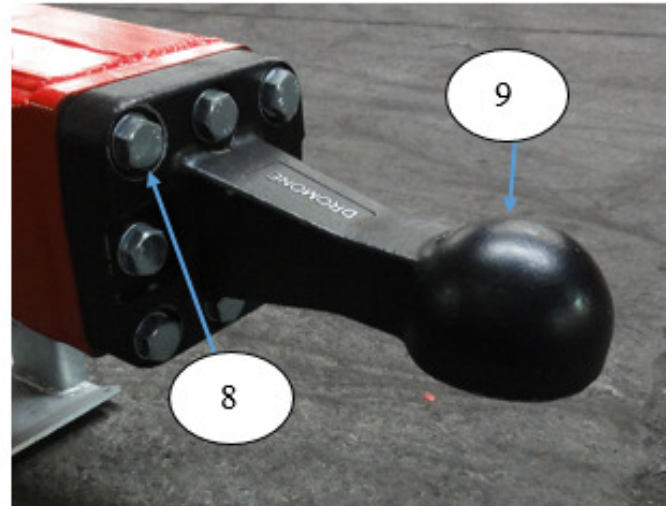
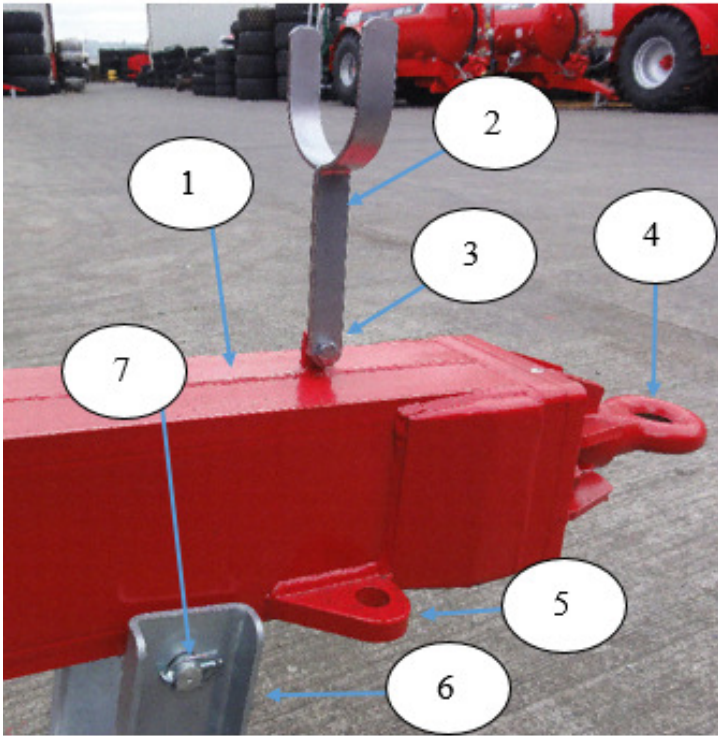

	Part No.	Description
1	DS/0162	Drawbar
2	MM/620	PTO stand
3	GP/1023 GP/1098 GP/1122	M12 x 40 bolt, nut & washer
4	MM/9210	Bolt on swivel hitch
5	DS/0158	Safety chain coupling (weld on)
6	DS/0159	Drawbar stand
7	DS/0160	Drawbar stand pin
	GP/2063	Drawbar stand linchpin
8	GP/1051 GP/1124	M20 x 50 bolt & washer
9	MM/9208	Bolt on spoon hitch
10	DS/161	Drawbar pin 50mm x 300mm
11	DS/0161	Drawbar pin End cap
12	GP/10511 GP/1124	M20 x 40 bolt & washer

Chain covers & hood fittings

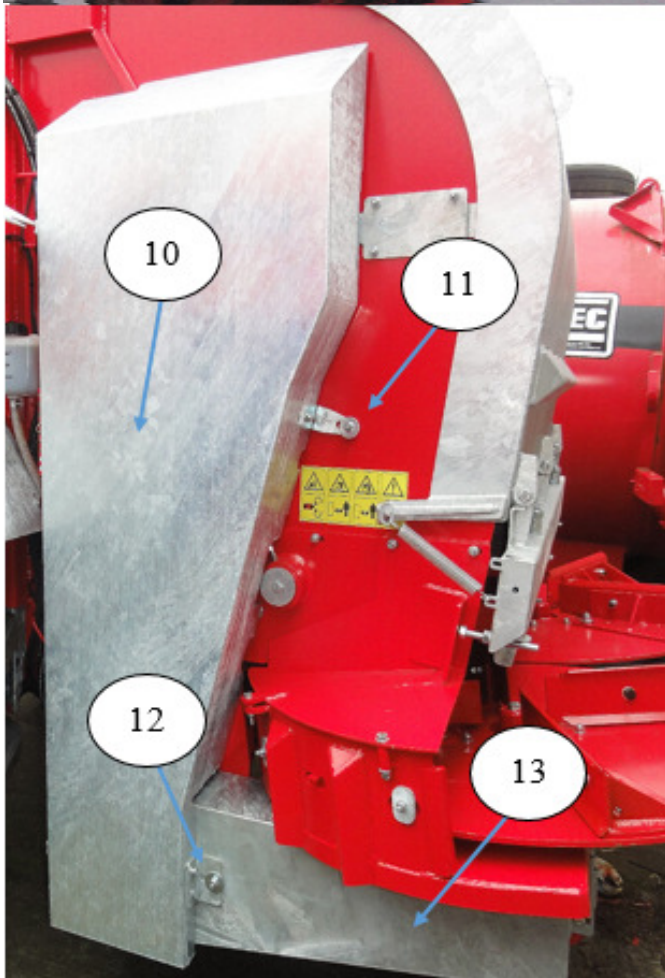
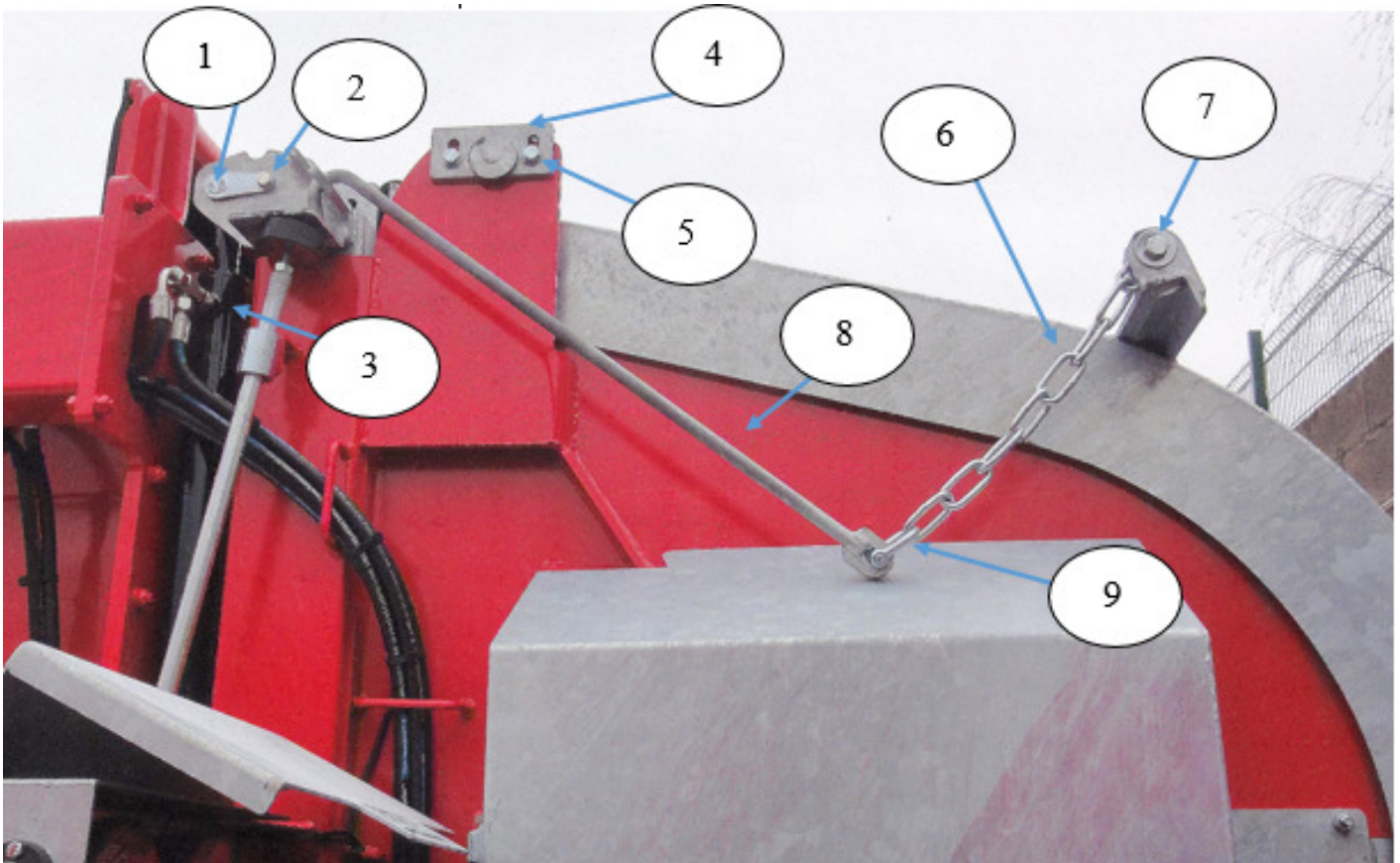

	Part No.	Description
1	DS/0163	Door ram pin 25mm x 80mm
2	GP/1015 GP/1097 GP/1121	M10 x 30 bolt, nut & washer
3	DS/0040	Door ram
4	DS/0164	Hood hinge cap
5	GP/1023 GP/1098 GP/1122	M12 x 40 bolt, nut & washer
6	DS/0184	Rear hood lift hook chain
7	GP/10751 GP/1102	M14 x 40 bolt, nut & oversized washer
8	DS/0165	Rear hood lift Hook
9	DS/0166	U bolt
10	DS/0167	Main chain guard
11	GP/1023 GP/1098 GP/1122	M12 x 40 bolt & oversized washer
12	GP/1023 GP/1098 GP/1122	M12 x 40 bolt & oversized washer
13	DS/0168	Lower chain guard

Chain oiler

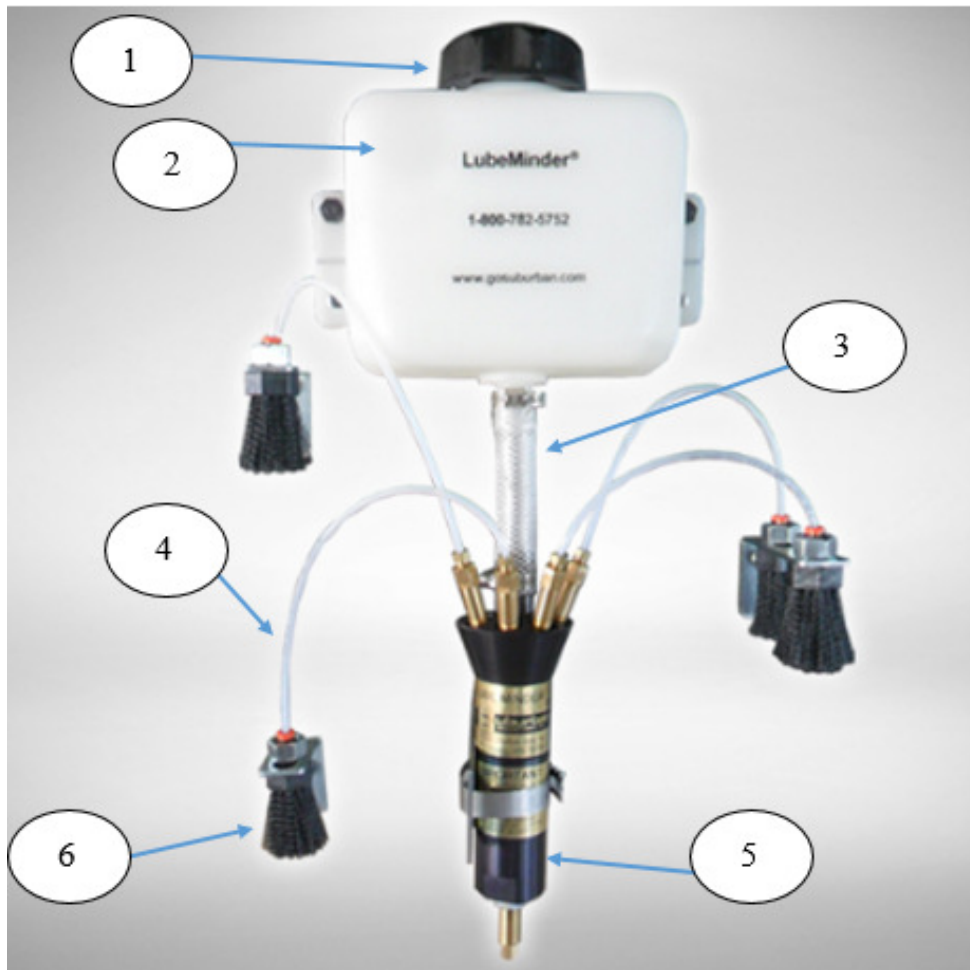

	Part No.	Description
1	MM/9875	Tank cap
2	MM/9871	Oil tank
3	MM/345	Hose (<i>please state length when ordering</i>)
4	MM/9872	Oil line
5	MM/987	Oil pump
6	MM/9877	Brush

Rubbers

	Part No.	Description	dimensions (mm)	Thickness (mm)
1	DS/0132	Front sealing rubber	1440 x 200 – 10 hole	10
1a	DS/0181	Front sealing rubber	1440 x 250 – 10 hole	10
2	DS/0133	Rear sealing rubber (fitted on slurry door)	1500 x 200 – 10 hole	10
2a	DS/0134	Rear sealing rubber (fitted on slurry door)	1500 x 250 – 10 hole	10
3	DS/0089	Rear throwback flap	1500 x 660 – 10 hole	10
4	DS/0135	Floor cleaner rubber	1414 x 140 10 hole	10
5	DS/0099	Perspex sight glass	585 x 430 – 5 hole	5
6	GP/1025	Bolt, nut and washer size	M12 x 60	

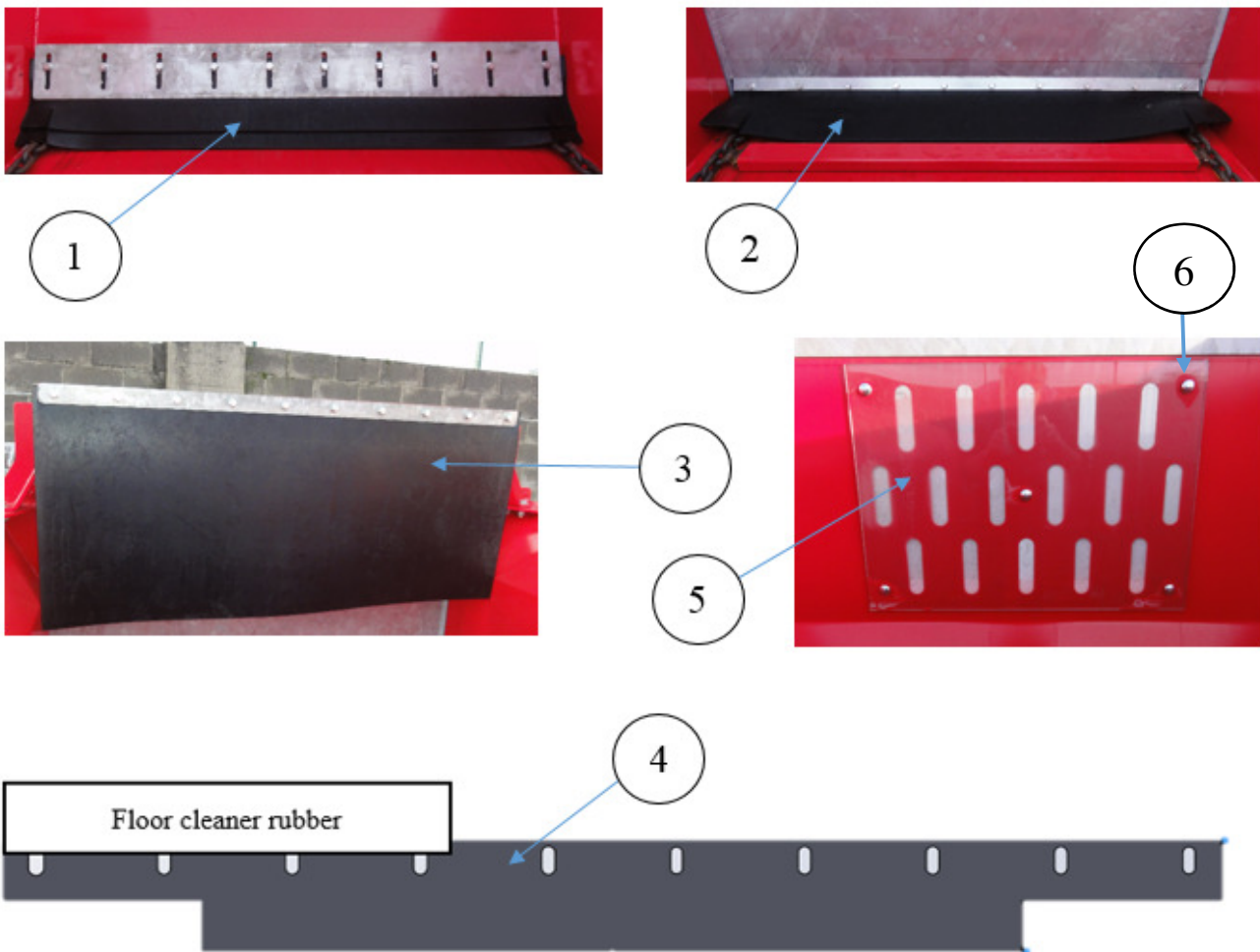



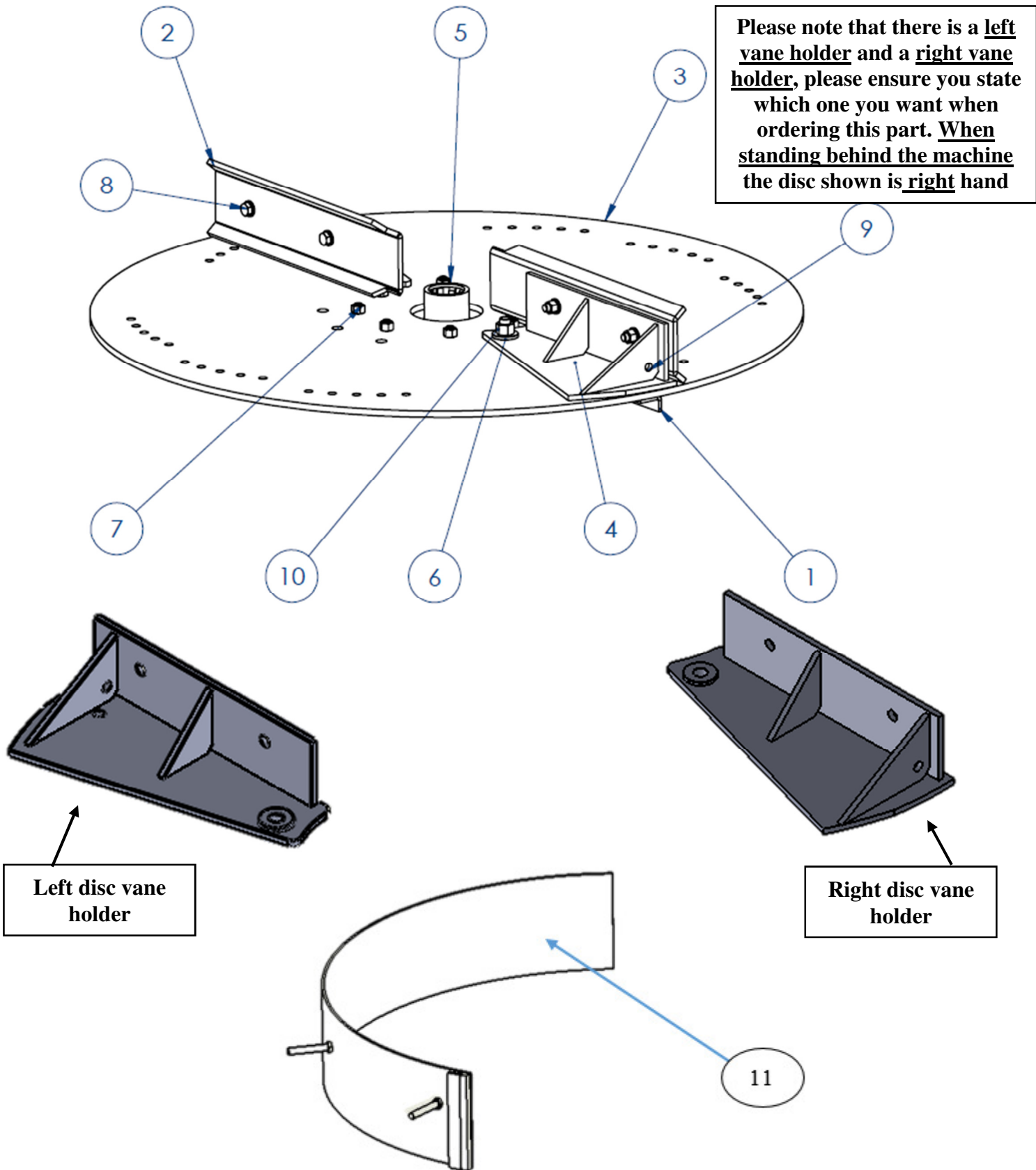

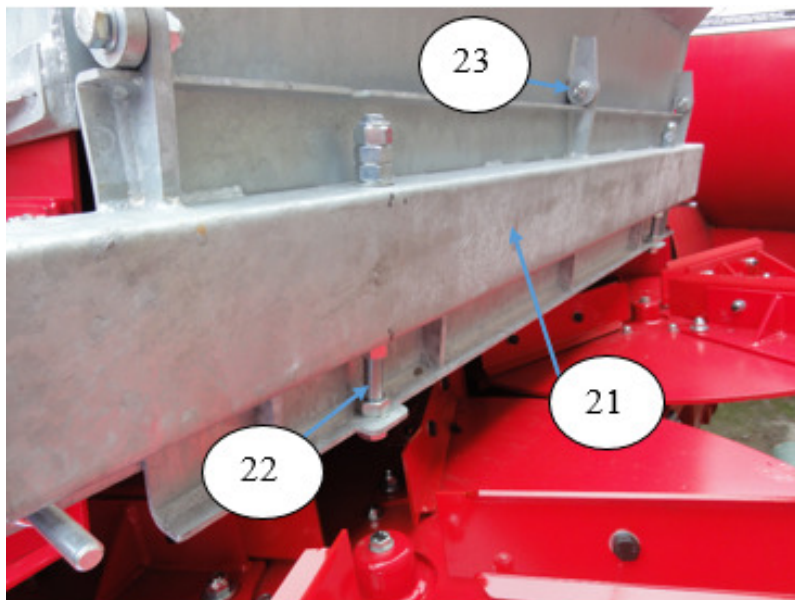
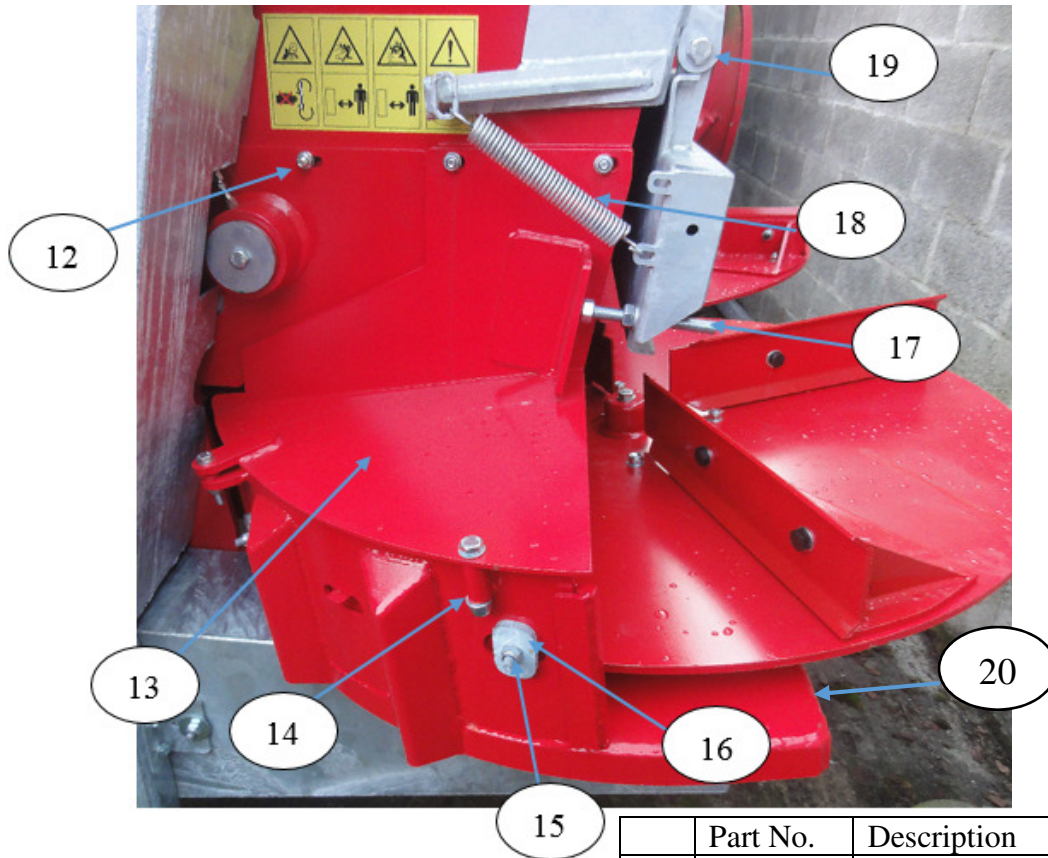



Spreading Disc and Vane Complete





	Part No.	Description
1	DS/0118	Spreading scraper
2	DS/0119	Hardox Vane
3	DS/0117	Spreading Disc
4	DS/0120	Vane holder right
	DS/0169	Vane holder left
5	DS/0116	Splined sleeve flange
6	DS/0121	Vane Bush
7	GP/1022	M12 x 35 Bolt
8	GP/10751	M14 x 40 Bolt
9	GP/1023	M12 x 40 shear Bolt
10	GP/1042	M16 x 50 Bolt
11	DS/0029	Spreading deck wear plate
12	GP/1016	M10 x 40
13	DS/0170	Rear spreading disc cover plate
14	GP/1026 GP/1098 GP/1122	M12 x 70 bolt, nut & washer
15	GP/1097	M10 nut
16	DS/0185	Retaining plate for wear plate
17	GP/1143	M16 x 150 threaded bar
18	DS/0124	Tensioner spring
19	GP/1075 GP/1102 GP/10932	M14 x 50 bolt, nut & washer
20	DS/0077	Spinner deck
21	DS/0127	Adjustable flap
22	GP/1104	M20 threaded bar, 6 nuts
23	GP/1075 GP/1102 GP/10932	M14 x 50 bolt, nut and washer

Decals

Ref.	Part No.	Description
1	ST/0028	
3	ST/001(large) ST/002 (small)	
4	ST/0043	
5	DS/0198	
6	DS/0199	
7	DS/0200	
8	DS/0201	
9	DS/0202	

Floor chain drive gearbox

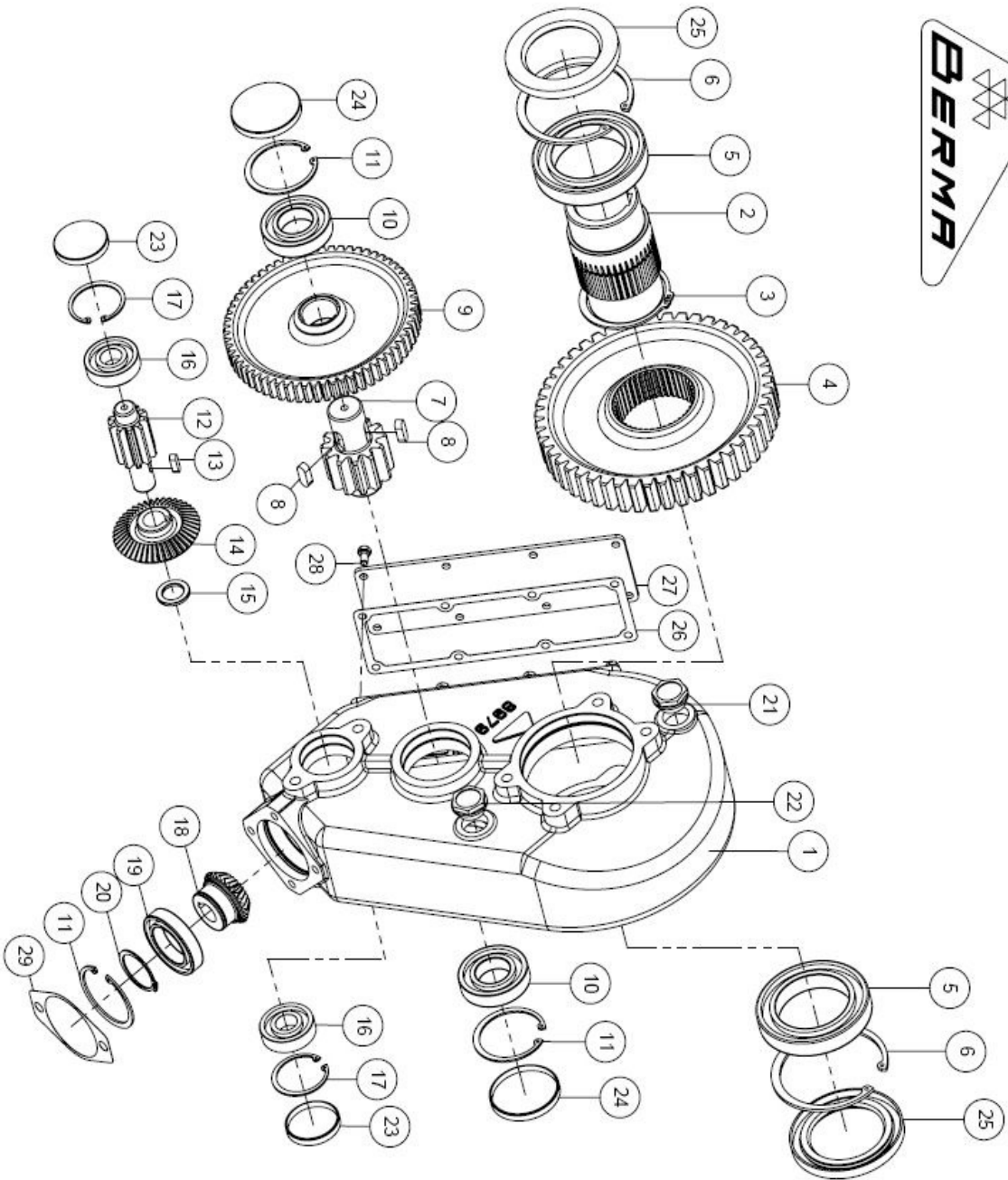

Riduttore RT500 Ø60		
CODICE 9063		
Fig.	Rif.	Descrizione Qt.
1	8979	Scatola RT500 1
2	8995	Mozzo Ø60 1
3	9066	Seeger E 95 1
4	8996	Ruota dentata Z=54 1
5	9067	Cuscinetto 6017 2
6	9069	Seeger I 130 2
7	9009	Pignone di rinvio Z=12 1
8	4174	Chiavetta 12x8x30 2
9	9007	Ruota dentata Z=63 1
10	10509	Cuscinetto 6208 -MP 2
11	3435	Seeger I 80 3
12	9008	Pignone di rinvio Z=10 1
13	3396	Chiavetta 8x7x25 1
14	8670-2	Corona conica Z=43 1
15	9010	Distanziale x corona 1
16	8596	Cuscinetto 6305 2
17	3433	Seeger I 62 2
18	8670-1	Pignone Z=28 1
19	1538	Cuscinetto 6010 1
20	3428	Seeger E 50 1
21	9175	Tappo sfiato Ø1" Gas 2
22	1831	Spia liv. olio Ø1"Gas 2
23	8625	Tappo Ø62 sp.10 2
24	8243	Tappo Ø80 sp.10 2
25	9068	Anello di ten. 85/130/12 2
26	9064	Guarnizione copercchio 1
27	9065	Copercchio x scatola 1
28	3284	Vite TE M8x16-8G 8
29	8671	Guarnizione x motore 1

Rear spreading spinners gearbox

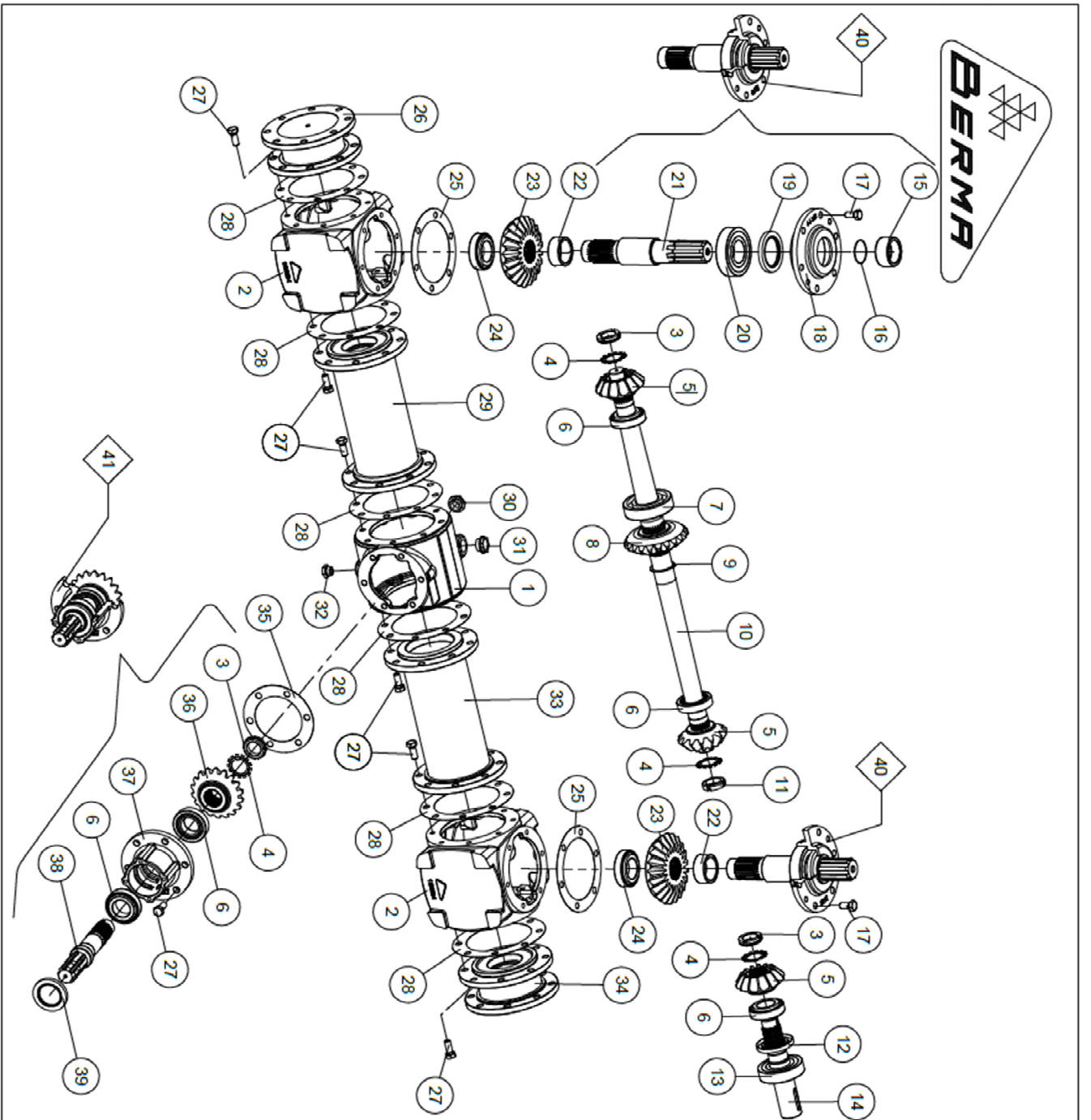

SRT18/1500-UL - 1000/520 - 7°			
CODICE 17575			
Fig.	Rif.	Descrizione	Qt.
1	14075	Scatola E.M.	1
2	12624	Scatola laterale	2
3	9137	Ghiera M40x1,5 sx.	3
4	9011	Rosetta x ghiera M40	4
5	9603	Pignone conico Z=14	3
6	1259	Cuscinetto 32209	5
7	1531	Cuscinetto 6311	1
8	9632	Corona conica Z=22	1
9	3430	Seeger E 55	1
10	12960	Albero c.c. L=1020	1
11	9138	Ghiera M40x1,5 dx.	1
12	4152	Anello di ten. 50x90x10	1
13	7749	Cuscinetto 6310-2RS	1
14	17585	Albero uscita laterale	1
15	9124	Distanziale x calotta	2
16	9139	Anello ØR 272 (ØS3,70x1,78)	2
17	4138	Vite TE M14x30	12
18	9111	Calotta	2
19	7481	Anello di ten. 70x100x10-DL	2
20	13103	Cuscinetto 6311-2RS	2
21	12645	Albero com. aspe	2
22	9123	Distanziale x corona	2
23	9604	Corona conica Z=22	2
24	3349	Cuscinetto 32210	2
25	9134	Guarnizione x calotta	2
26	17582	Distanziale est. L=86	1
27	3549	Vite TE M14x35	54
28	9135	Guarnizione x scatola	6
29	17580	Distanziale dx. L=343	1
30	9179	Spia liv. olio Ø1"Gas All.	1
31	9301	Tappo sfiato Ø1"Gas zinc.	1
32	9707	Tappo Ø1/2"Gas zinc.	1
33	17581	Distanziale sx. L=343	1
34	17584	Distanziale U.L. L=86	1
35	9133	Guarnizione x mozzo	1
36	9631	Pignone conico Z=18	1
37	9127	Mozzo E.M.	1
38	9053	Albero E.M.	1
39	7480	Anello di ten. 55x85x10-DL	1
40	12657	Calotta completa	2
41	14203	Mozzo E.M. comp.	1

PTO Shafts

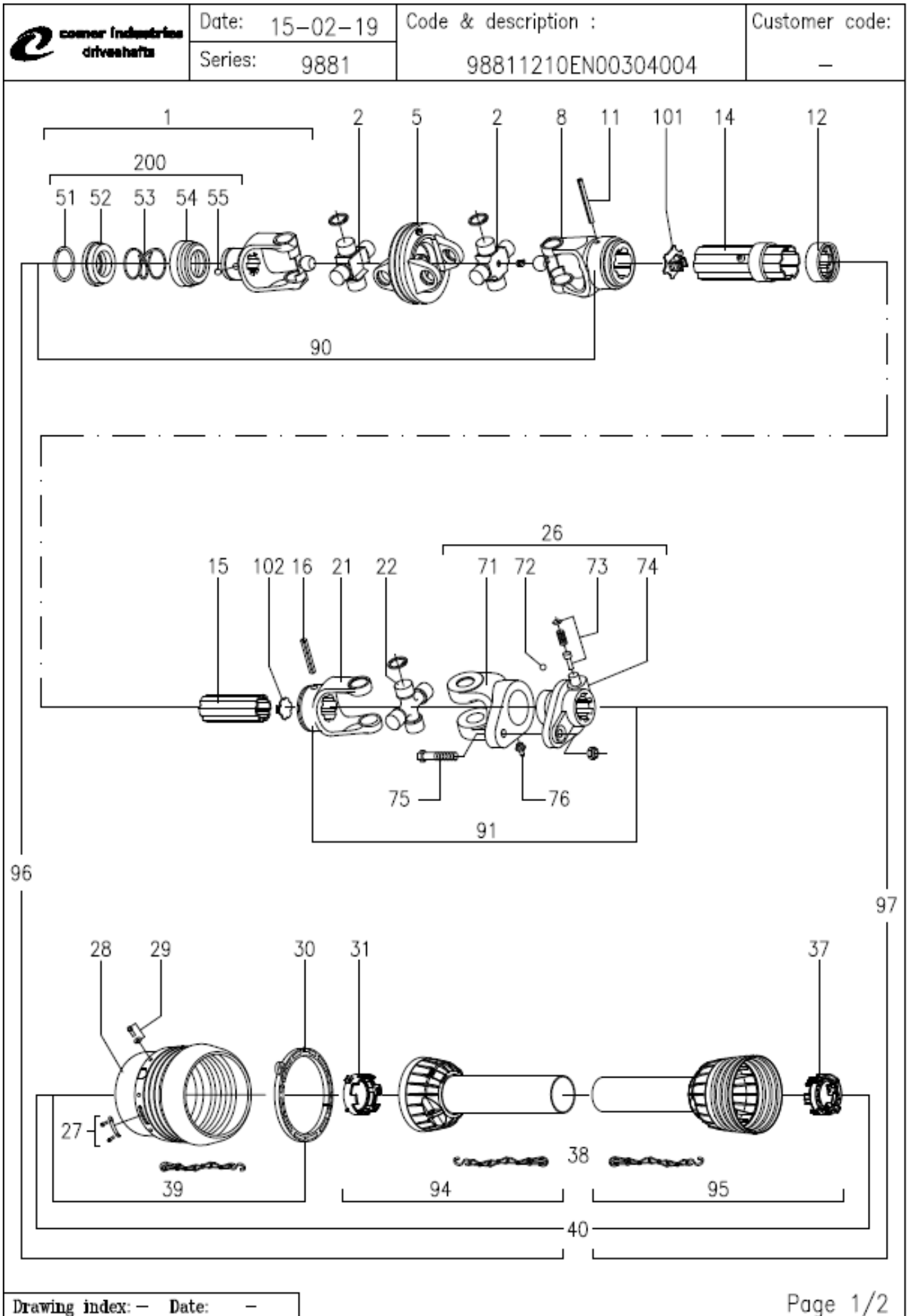

Drawing index: - Date: -

	Date: 15-02-19	Code & description :	Customer code:
	Series: 9881	98811210EN00304004	-

Pos.	Description	Q.ty	Code	Pos.
1	Complete collar yoke for CV-joint C02 (1 3/8" Z6)	1	141.028.358.1	1
2	Cross journal set for CV-joint	2	180.018.158	2
5	Wide angle double yoke	1	141.028.472.1	5
8	Outer yoke	1	141.028.248.1	8
11	Roll pin for outer tube	1	190.000.243	11
12	Wiper	1	180.018.437	12
14	Complete outer tube	1	150.281.512.0730	14
15	Inner tube	1	159.280.168	15
16	Roll pin for inner tube	1	190.000.271	16
21	Inner yoke	1	151.018.242.1	21
22	Cross journal set	1	180.018.004	22
26	Complete shear bolt B04 (2500Nm)	1	143.280.052.1	26
27	Set sheet & screw	1	165.000.790	27
28	Guard cone for wide angle CV-joint	1	180.028.548	28
29	Set screw	6	165.000.694	29
30	Bearing ring	1	158.018.470	30
31	Guard retaining collar for outer tube	1	180.019.353	31
37	Guard retaining collar for inner tube	1	180.019.354	37
38	Safety chains	3	180.016.790	38
39	Guard cone set	1	165.000.784	39
40	Complete guard with instruction manual	1	142.981.582.2851	40
51	Circlip	1	190.000.451	51
52	Sliding sleeve collar	1	151.016.486	52
53	Spring	1	180.016.487	53
54	Fixed sleeve	1	180.016.483	54
55	Ball ϕ 1/2"	3	190.000.078	55
71	Yoke for hub B (55xM10)	1	151.018.368.1	71
72	Ball ϕ 5/16"	24	190.000.023	72
73	Push pin set 1 3/4"	2	166.026.005	73
74	Hub B04 (55xM10)-(1 3/4" Z6)	1	141.026.044.1	74
75	Bolt & nut M10x60 c1.8.8	6	165.000.507	75
76	Grease fitting M10x1	1	190.000.021	76
90	Wide angle CV-joint for outer tube	1	121.028.969.01	90
91	U Joint for inner tube	1	121.028.104.01	91
94	Half female guard	1	142.386.102.2851	94
95	Half male guard	1	142.387.090.2851	95
96	Half female shaft with guarding	1	199811210EN11304	96
97	Half male shaft with guarding	1	123.686.278.01	97
100	Instruction manual	1	190.000.692	100
101	Outer cap	1	180.018.393	101
102	Inner cap	1	180.018.435	102
200	Kit collar 1 3/8"	1	165.000.628	200

Drawing index: - Date: -

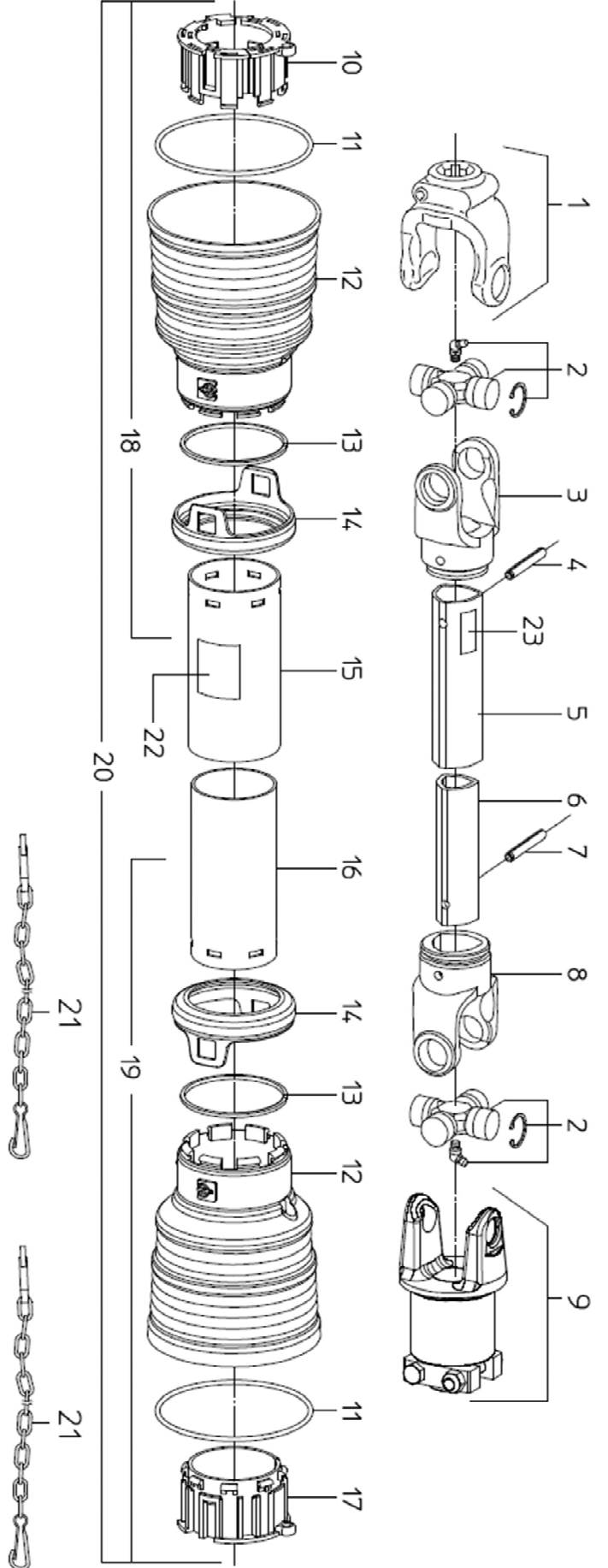

13	2	STOP RING	1218035	26						
12	2	STANDARD CONE	1788023	25						
11	2	STIFFENING RING	1218033	24						
10	1	TUBE BEARING (outer tube)	1788016	23	1	INNER DECAL				1140003
9	1	FREE WHEEL (RF3)	1768284	22	1	OUTER DECAL				1140001
8	1	INNER TUBE YOKE	1708029	21	2	ANTIROTATION CHAIN				1006065
7	1	10x90 1485DIN ROLL PIN (inner tube)	6331090	20	1	COMPLETE PROTECTION				96SS8095
6	1	INNER TUBE	1528106	19	1	HALF INNER PROTECTION				96XS8095
5	1	OUTER TUBE	1530106	18	1	HALF OUTER PROTECTION				96SX8095
4	1	10x90 1485DIN ROLL PIN (outer tube)	6331090	17	1	TUBE BEARING (inner tube)				1788017
3	1	OUTER TUBE YOKE	1708027	16	1	INNER TUBE SHIELD				1879095
2	2	CROSS ASSEMBLY	1008020	15	1	OUTER TUBE SHIELD				1878095
1	1	YOKE ASSEMBLY (TRACTOR END)	1038020	14	2	SAFETY SLEEVE				1888009

DET.	QTY	DESCRIPTION	CODE	DET.	QTY	DESCRIPTION	CODE

temporary:		weight (kg/lb):	
customer part no:	THE RELIANCE		
title:	SPARE PARTS LAY-OUT		
description:	AX8 1250/4593 1038020-1768284 CP SS		

nome:	date:	R.A.T.:	temporary:	note:	weight (kg/lb):

nome:	date:	R.A.T.:	temporary:	note:	weight (kg/lb):

nome:	date:	R.A.T.:	temporary:	note:	weight (kg/lb):

nome:	date:	R.A.T.:	temporary:	note:	weight (kg/lb):

nome:	date:	R.A.T.:	temporary:	note:	weight (kg/lb):

nome:	date:	R.A.T.:	temporary:	note:	weight (kg/lb):

nome:	date:	R.A.T.:	temporary:	note:	weight (kg/lb):

nome:	date:	R.A.T.:	temporary:	note:	weight (kg/lb):

nome:	date:	R.A.T.:	temporary:	note:	weight (kg/lb):

nome:	date:	R.A.T.:	temporary:	note:	weight (kg/lb):

nome:	date:	R.A.T.:	temporary:	note:	weight (kg/lb):

nome:	date:	R.A.T.:	temporary:	note:	weight (kg/lb):

nome:	date:	R.A.T.:	temporary:	note:	weight (kg/lb):

nome:	date:	R.A.T.:	temporary:	note:	weight (kg/lb):

nome:	date:	R.A.T.:	temporary:	note:	weight (kg/lb):

nome:	date:	R.A.T.:	temporary:	note:	weight (kg/lb):

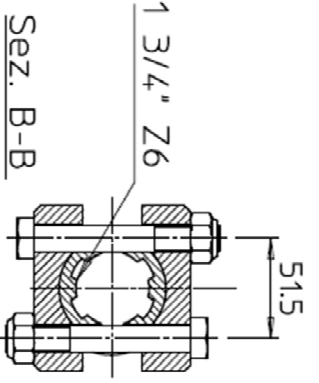
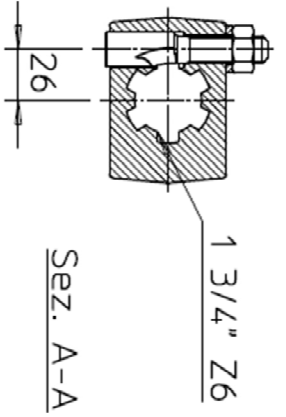
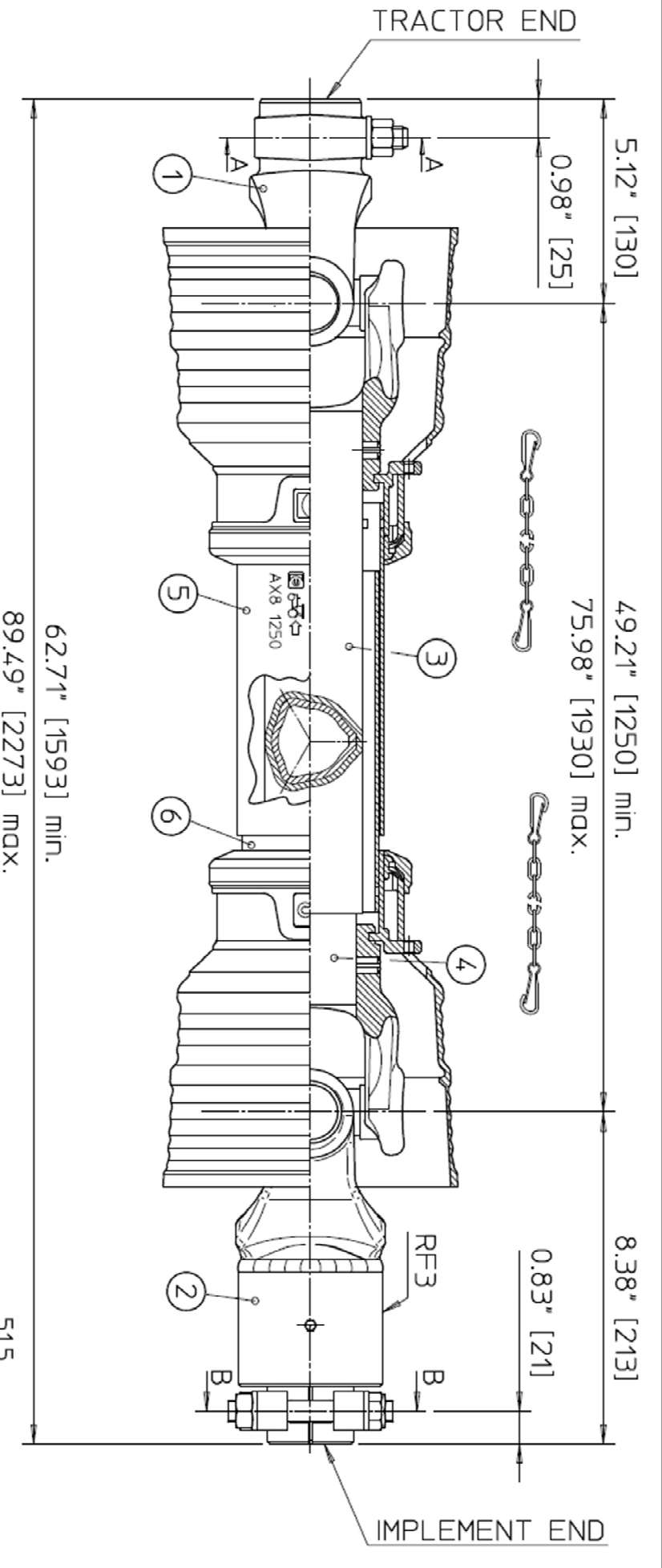

n.	code	tube/yoke	rev.	description	name	date	R.A.T.
6	1879095						
5	1778095						
4	1528106	1918106N					
3	1530106	1908106N					
2	1768284						
1	1038020						

EUROCARDAN ENERGY ON THE MOVE		FORMA AX8 disegnato da: V. DI GIOVANNI scale: NO data: 18/02/2019 A4	
via Firenze n.25 Z.L. 66041 Alassio (CH) - Italy			
Customer part no: THE RELIANCE		Temporary:	
title: AX8 1250/1593 1038020-1768284 CP SS		part no: AX85000-0088	
		rev: -	

Drive shafts and Carrier Bearings

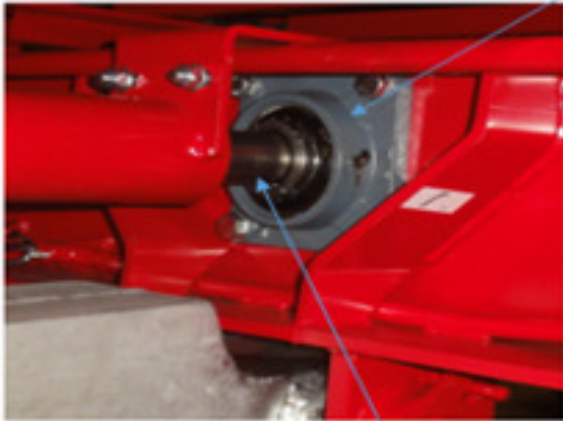



Reference	Part number	Description
1	MM/0551	FX11 taper lock carrier bearings
2	DS/0030	50 mm Solid Drive shaft long M/M (2960mm)
3	DS/0174	50mm Solid Drive shaft short M/M (1740mm)
4	DS/0095	Mid-section telescopic PTO shaft F/F complete (<i>see pages 32, 33</i>)
5	DS/0094	Double coupling F/F

Drive shaft covers

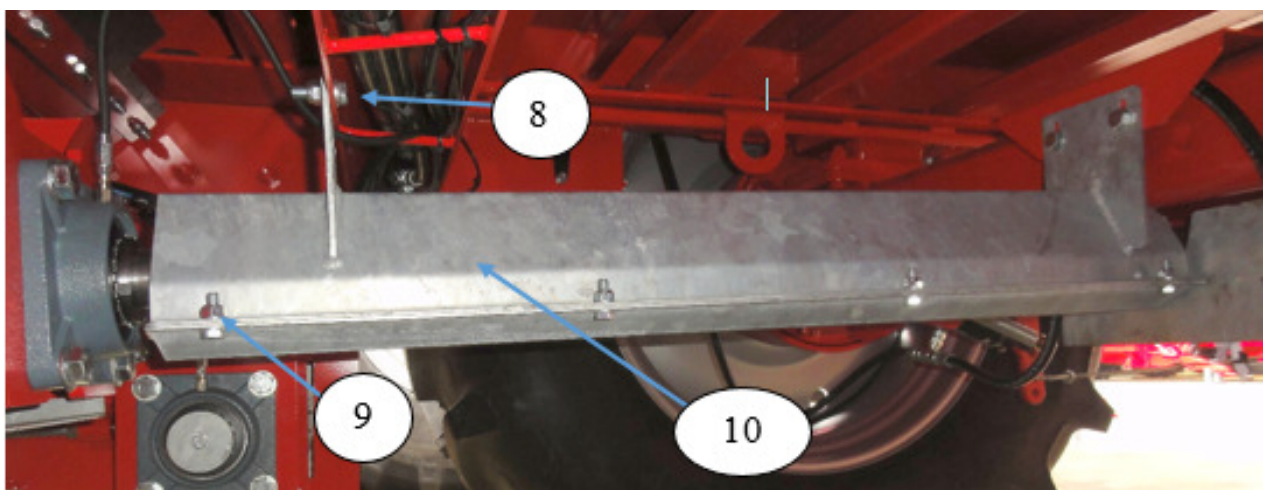
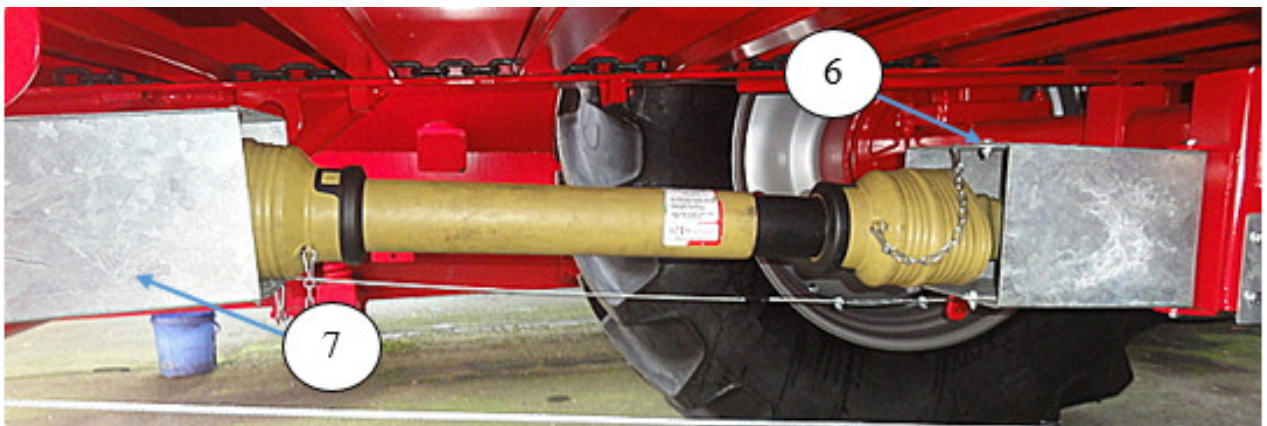
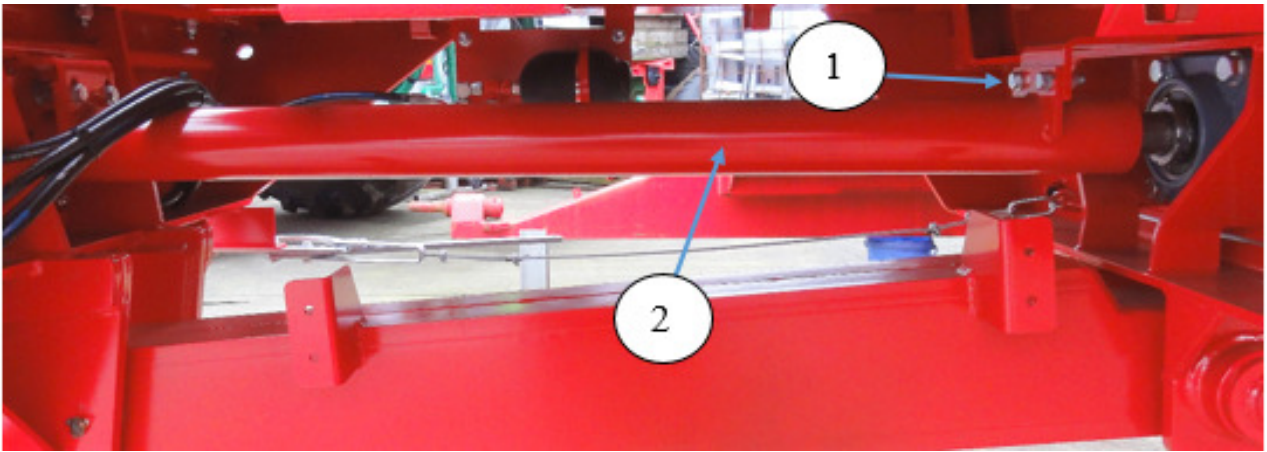

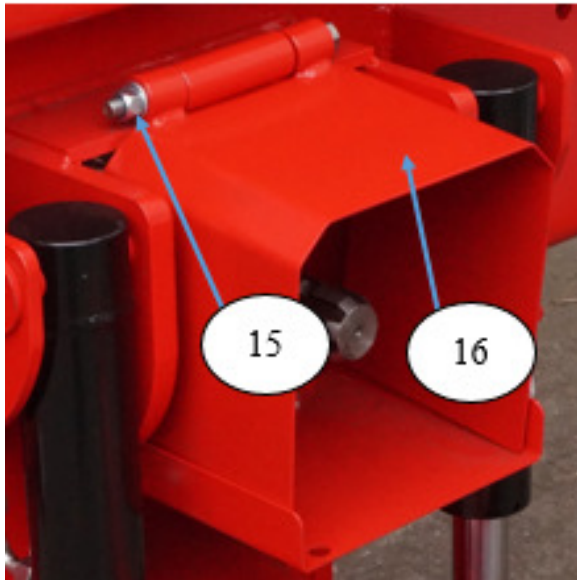
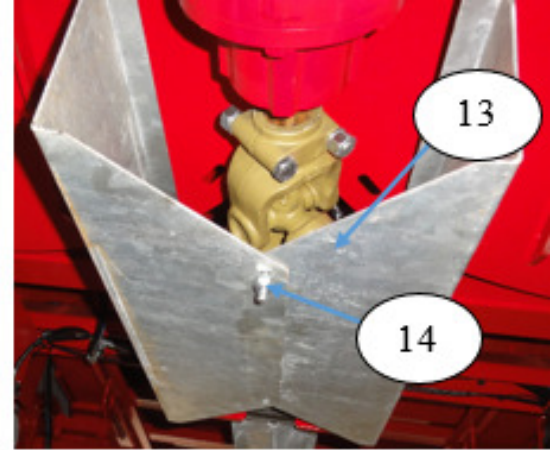
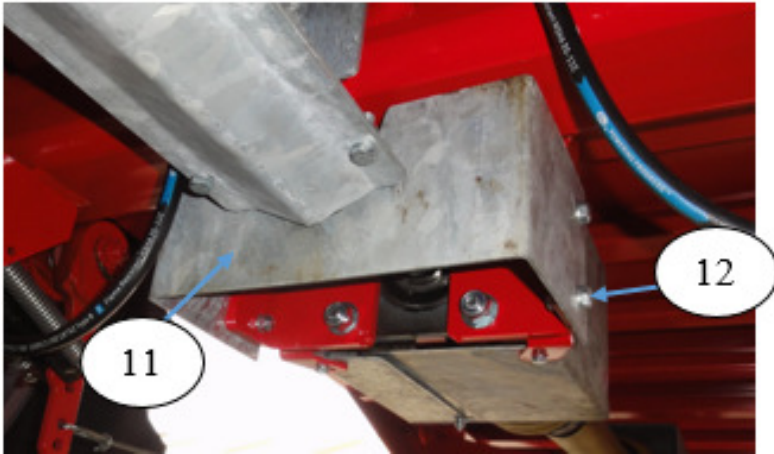

	Part No.	Description
1	GP/1023 GP/1098 GP/1122	M12 x 40 bolt, nut and washer
2	DS/0175	Steel cover for long shaft (1285mm)
3	GP/1023 GP/1098 GP/1122	M12 x 40 bolt, nut and washer
4	DS/0176	Steel cover for long shaft (950mm)
5	GP/1108 GP/1103 GP/1148	M18 x 60 bolt, nut & washer
6	GP/1006 GP/1096 GP/1120	M8 x 20 bolt, nut & washer
7	DS/0177	Mid-section galvanized PTO covers
8	GP/1023 GP/1098 GP/1122	M12 x 40 bolt, nut & washer
9	GP/1015 GP/1097 GP/1121	M10 x 30 bolt, nut & washer
10	DS/0178	Galvanized cover for short shaft
11	DS/0179	Galvanized end guard for short shaft
12	GP/1015 GP/1097 GP/1121	M10 x 30 bolt, nut & washer
13	DS/0180	Double coupling galvanized cover
14	GP/1015 GP/1097 GP/1121	M10 x 30 bolt, nut & washer
15	GP/1035 GP/1098 GP/1121	M12 x 170 bolt, nut & washers
16	DS/0067	PTO cover

Axles

PROPERTY AND CONFIDENTIAL:
THE INFORMATION CONTAINED IN THIS
DRAWING IS THE SOLE PROPERTY OF
DISTAG QCS. ANY REPRODUCTION IN PART
OR WHOLE WITHOUT THE WRITTEN
PERMISSION OF DISTAG QCS IS PROHIBITED.

Spare Parts List

1402719

Part Number:	D150H-4218-2324-B2-00
Model ref:	HS14A1008-00

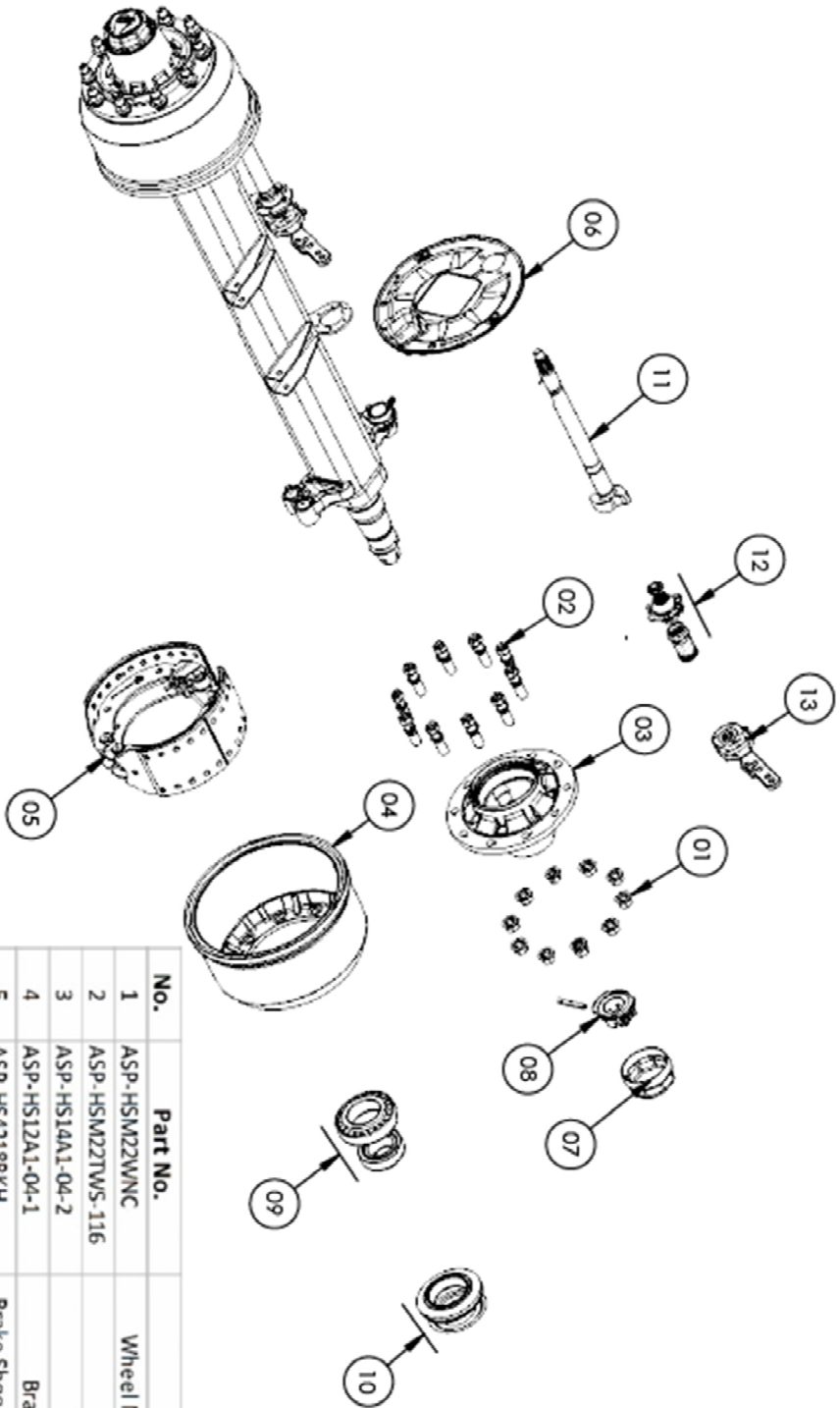

No.	Part No.	Description	Qty
1	ASP-HSM22WNC	Wheel Nut & Conical Washer Kit	2
2	ASP-HSM22TWS-116	Wheel Stud Kit	2
3	ASP-HS14A1-04-2	Wheel Hub	2
4	ASP-HS12A1-04-1	Brake Drum ($\phi 420 \times 180$)	2
5	ASP-HS42188KH	Brake Shoe Replacement Kit ($\phi 420 \times 180$)	2
6	ASP-HS12A1-02-AK	Dust Cover Kit	1
7	ASP-HS14A1-09	Hub Cap	2
8	ASP-HS14A1-11-AK	Castle Nut & Split Pin Kit	2
9	ASP-HS33215-33219	Bearing Kit	2
10	ASP-HS14A1-05-AK	Seal Replacement Kit	2
11	ASP-HS12A1-14-1 (S)	Camshaft (S Type) (587mm)	1
12	ASP-HS12A1-14-1 (Z)	Camshaft (Z Type) (587mm)	1
13	ASP-HS12A1-14-AK	Camshaft Repair Kit	2
	ASP-HS12A1-14-13(68)	Slack Adjuster	2

Wheel & Tyre Assembly



	Wheel size	
1	570/80 R38	WHL/0041
2	650/75 R32 BKT	WHL/002



Sales and Service

Ireland

Head office

Hi-Spec Engineering Ltd., Station Rd, Bagenalstown, Co. Carlow, Ireland

Tel: - +353 59 9721929 Fax: - +353 59 9721980

Email: - sales@hispec.net or info@hispec.net

Sales

Contact: - Eoin Keane, Hi-Spec Engineering Ltd. Tel: - +353 87 2562963

Email: - eoin@hispec.net

Machine Servicing

Contact: - Michael Brennan, Hi-Spec Engineering Ltd. Tel: - +353 87 2403312

Spare Parts Store

Contact: Mike Nolan or Terence Byrne, Hi-Spec Engineering Ltd.

Tel: - +353 59 9721929 Fax: - +353 59 9721980

Email: - stores@hispec.net

U.K.

Sales

Wales & Southern England

Contact: - Edward Lewis, Hi-Spec Engineering Ltd. Tel: - +44 7876 452698

Email: - elewis@hispec.net

Scotland & Northern England

Contact: - Gordon Brodie, Hi-Spec Engineering Ltd. Tel: - +44 7799 905130

Email: - gordon@hispec.net

For spare parts

Contact: - Your local Hi-Spec dealer. If you require a contact name and number you can telephone head office and we would be glad to assist you.