



Manufacturers of Agricultural Machinery

Hi-Spec XCEL 1250

Operators Manual



rev - xl101

Hi-Spec Engineering Ltd.

Station Rd, Bagenalstown, Co. Carlow

Tel: +353 (0) 59 -9721929 / 9721992

Fax: +353 (0) 59 -9721980

Website: www.hispec.net

E-mail: sales@hispec.net



Parts are subject to change at any time, without prior or direct notice to the customer. The contents of this manual can as well be changed without prior notice. For information about adjustment, maintenance or repair, which are not mentioned in this manual, you are advised to consult the technical support of your supplier.

This manual has been made with all possible effort, but Hi-Spec Engineering and its suppliers cannot be responsible for possible mistakes in this manual, nor for the consequences.

Introduction

Congratulations on Purchasing a Hi-Spec XCEL 1250 Spreader.

Please Read the Following Manual Before Using Machine

The way you care for and maintain this machine will decide its future performance. This manual has been carefully written to help you maintain the condition of your machine. Read this manual carefully to learn how to operate and service your machine correctly. Failure to do so could result in personal injury or machine damage.

Hi-Spec XCEL 1250s have been designed and manufactured in compliance with the following directives and standards;

Machinery Directive 2006/42/EEC

Harmonised standards;

EN ISO 12100-1:2003, Safety of machinery Part 1: Basic terminology, methodology

EN ISO 12100-2:2003, Safety of machinery Part 2: Technical principles

EN ISO 4254-1:2005, Agricultural machinery -- Safety -- Part 1: General requirements

EN ISO 14121-1:2007, Safety of Machinery – Principle of Risk Assessment

This manual should be kept within the vicinity of the machine at all times and should be considered a permanent part of your machine. It should remain with the machine should you decide to sell it.

Warranty is provided as a part of Hi-Spec Engineering's support program for customers who operate and maintain this machine and equipment as described in this manual. This warranty provides you the assurance that Hi-Spec Engineering will back its machines should defects appear within the warranty period. If the machine is abused, or modified to change its performance beyond the original factory specifications, the warranty will become void and improvements may be denied.

All information, illustrations and specifications in this manual are based on the latest product information available at the time of publication.

It is the policy of Hi-Spec Engineering to improve its products and designs whenever it is practical and possible to do so. We reserve the right to make changes or improvements at any time without incurring any obligation to make such changes on products sold previously

Thank You for Choosing Hi-Spec Engineering

Contents

Introduction.....	3
Contents	4
Designated Use of Machine.....	6
Technical Specifications and Dimensions.....	7
Safety.....	8
General Safety.....	8
Safety Checklist	9
Description of Safety Warnings and Instructions.....	11
PTO Shaft Safety.....	14
Machine Overview.....	15
Getting Started	16
Tractor Requirements	16
Hydraulic Requirements.....	16
Connecting to Tractor	17
Fitting PTO Shaft.....	19
Road Transportation.....	20
Emergency Breakaway Handbrake.....	21
Operating Instructions.....	23
Loading Instructions	24
Spreading Instructions.....	25
Spreading flow-able material (slurries, sewage pellets etc.)	26
Maintenance.....	27
Correct Maintenance and Inspection Procedures	28
Recommended Maintenance	28
Tyre Details.....	29
Wheel removal/refitting	31
General Repairs	34
Chain Flail Shortening.....	34
Rotor Main Drive Chain Tensioning	34
Floor Chain Cross-Slat Replacement	35
Chain Flail Head Replacement.....	36



Replacing Rear Spinners Worn Plates	36
Fitting Fine Manure Spreading Discs.....	37
Spread-Splitter	Error! Bookmark not defined.
Sales and Service	38
Warranty.....	39
Conditions of Sale	40
Registration Forms	43
Declaration of Conformity	47

Designated Use of Machine

The Hi-Spec Xcel 1250 Muck spreader is exclusively designed for use of transporting and spreading agricultural manure.

Hi-Spec Engineering will not be held responsible for any loss or damage resulting from machine applications other than those specified above. Any other use the machine may be put to is entirely at the owners/operators risk. The Designated use of an Xcel 1250 includes that the operating, maintenance and repair instructions given by the manufacturer will be strictly fulfilled. Designated use means operating the Xcel1250 is exclusively for persons familiar with the machine and fully aware of the associated risks involved in operating it.

By any alteration of safety equipment, the Declaration of Conformity, as well as the CE sign on machine loses its validity

Technical Specifications and Dimensions

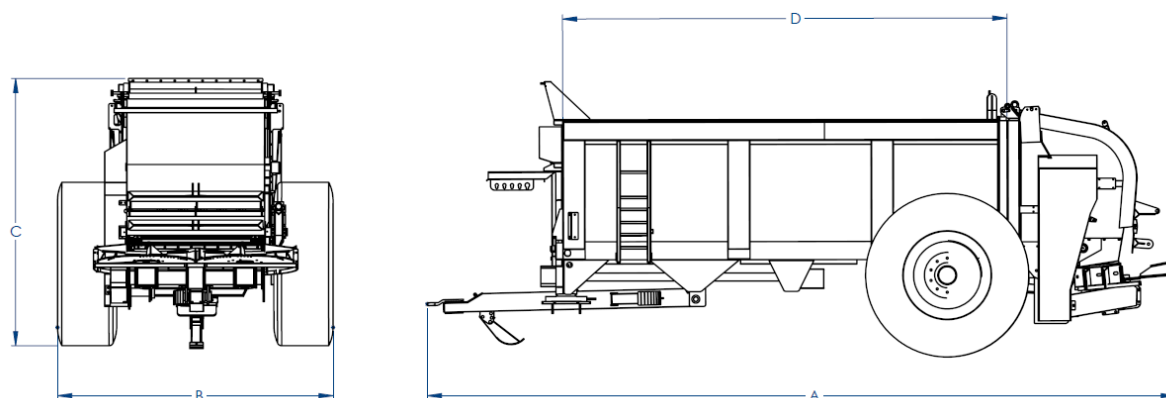

Technical Specification	
Loading Height	2550mm / 8'4"
Overall Length	<i>A</i> 8345mm / 27'4"
Overall Width	<i>B</i> 3060mm / 10'
Overall Height	<i>C</i> 3085mm / 10'1"
Length of Body	<i>D</i> 4985mm / 16'4"
Overall Height (with Slurry Door up)	4345mm / 14'3"
Capacity	11.5m ³ – Water Level 14.5m ³ – Heaped
Carrying Capacity	13 tonnes
Spread Width	Up to 24m
Unladen Weight	7000kg

Safety

General Safety

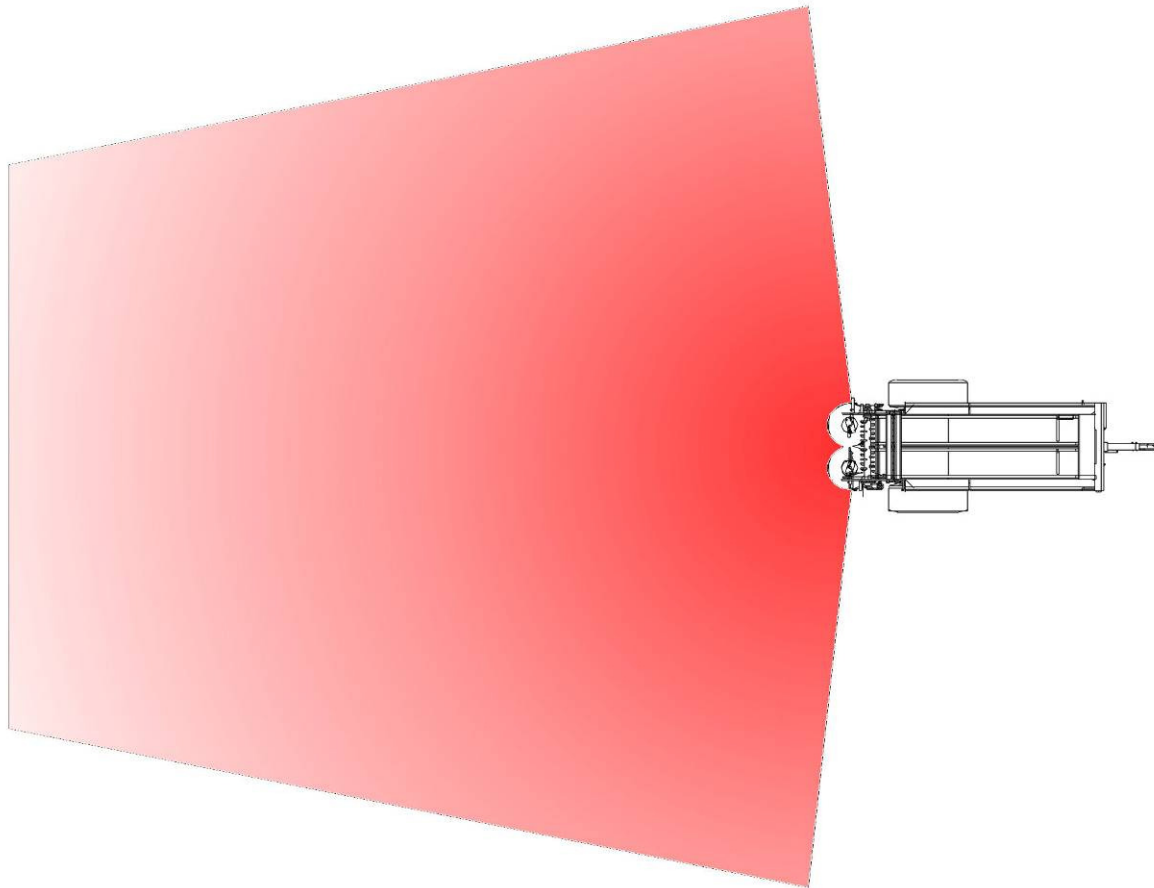

DANGER ZONE

Distances may vary depending on material being spread

Diagram for illustration purposes only

- ⚠ IF PTO IS ENGAGED, NO UNBLOCKING, CHECKING, SETUP OR SERVICING IS ALLOWED AND NO PERSON IS ALLOWED IN THE DANGER ZONE
- ⚠ PTO MUST BE DISENGAGED BEFORE CARRYING OUT ANY OF THE ABOVE ACTIONS
- ⚠ Keep a first-aid kit and a fire extinguisher close by at all times, if possible, on your tractor with this operator instruction manual.
- ⚠ Have an emergency plan.
- ⚠ Keep all emergency numbers close by; write them into your manual.
- ⚠ Inspect your machine carefully each time before use; this will only take a minute.

- ⚠ Always climb the ladder and check inside the machine before starting or filling it, to make certain it is empty.
- ⚠ Stop machine when leaving unattended.
- ⚠ Children should never be in the area when your Xcel 1250 is in operation.
- ⚠ Using an Xcel 1250 is a one-man operation therefore there should be no other person(s) in the vicinity of the machine while in use.
- ⚠ Remember that the first step to avoiding danger is to recognise the hazards.

Safety Checklist

- ✓ Always disconnect all power sources before carrying out any adjustment or maintenance.
- ✓ Always check inside the machine to make sure it is empty.
- ✓ Always check around the machine making sure everything is in order; this will only take a minute.
- ✓ Study this manual. Provide training to new users. Like all farm machinery, any machine is potentially dangerous when under the control of untrained personnel.
- ✓ Exercise extreme care when loading manure into the machine.
- ✓ Always ensure guards and other safety devices are kept in good working order. Replace if necessary.
- ✓ Keep clear of all moving parts.
- ✓ Always use shear bolts recommended to you by Hi-Spec Engineering.
- ✓ Always keep all hydraulic hoses and electric cables clear from PTO shaft.
- ✓ Always apply the handbrake before unhitching and park the machine in a level area.
- ✓ Always use the ladder for inspecting inside the machine. Do not climb up the side of the machine.
- ✓ Always take extra precautions when using the machine on hilly or sloping ground.
- X Never permit young persons or spectators to operate PTO driven equipment or stand anywhere close by when the machine is in operation.
- X Never permit untrained personnel to operate the machine without reading this manual and or receiving training.
- X Never operate the machine without having all guards in place; they are there for your safety and protection against serious injury and death.

- X Never remove guards while there is still power going into the machine, all power must be off!
- X If PTO is engaged, no unblocking, checking, set-up or servicing is allowed.
- X If PTO is engaged, no person is allowed in the danger zone.
- X Never enter the machine while in operation.
- X Never wear loose clothes when operating machinery, if standing too close, your clothing can pull you into the machine.
- X Never operate the machine if you think there could be large stones or foreign objects inside, they could cause serious damage to your machine.
- X Never leave the machine running when unattended.
- X If the machine should become blocked with a stone or foreign object. Do not attempt to free the object while the tractor is running.

Description of Safety Warnings and Instructions

- The decals consist of a picture representing the danger and a picture to show how to avoid it.
- You will find these signs located near specific hazards on your machinery.
- Please pay attention to these signs for your own safety.
- Safety signs should be maintained and replaced when necessary. They must be kept clean and clearly legible.
- If you need a replacement sign or have lost your user manual you must not operate the machine. Please contact your Hi-Spec authorised dealer or Hi-Spec Engineering directly and we will issue you a replacement.

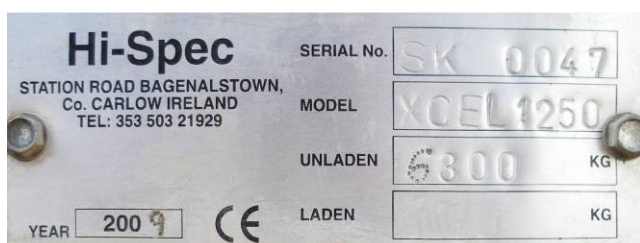

Serial Plate

Shows serial no, model type and company information



This is to remind users to perform these simple tasks regularly



This is to remind users always disengage the PTO when not operating the machine



This is to remind users to always stay clear of moving parts as they can cause serious injury



This is to remind users to read this manual and become familiar with it before using the machine

		! DANGER Rotating parts can cause serious injuries. Stones or other objects can cause serious injuries. Always keep a safe distance when machine is operating.

This is to remind users about the dangers of moving parts and objects that are ejected from the machine

		! WARNING Moving parts can cut and crush. Never touch any moving part when the machine is operating.
--	--	--

This is to remind users about the dangers of moving parts

CHECK ROTOR BOLT TIGHTNESS EVERY 50 OPERATING HOURS TORQUE - 550 Nm
--

This is to remind users to perform these simple tasks regularly as part of maintaining the machine

	<p style="text-align: center;">Warning</p> <p>Always read the operating manual and safety instructions before use.</p>
	<p style="text-align: center;">Warning</p> <p>When the machine is operating stones or other objects can cause injuries. Always keep a safe distance.</p>
	<p style="text-align: center;">Warning</p> <p>After the first operating hour and then every 25 operating hours, check tyre pressure and tighten wheel nuts.</p>
	<p style="text-align: center;">Warning</p> <p>PTO shafts can cause serious injury or death. Stay out of range of shaft and wear close fitting clothing.</p>
	<p style="text-align: center;">Warning</p> <p>When the machine is moving never stand between the tractor and the manure spreader.</p>
	<p style="text-align: center;">Warning</p> <p>Touching any rotating parts can cause serious injuries. Always keep a safe distance when machine is operating.</p>
	<p style="text-align: center;">Warning</p> <p>Fingers can be cut off between belts/chains and gearwheels. Always ensure safety guards are in place.</p>
	<p style="text-align: center;">Warning</p> <p>Gearwheels and rotating parts can cause serious injuries. Never touch rotating parts when the machine is operating.</p>
	<p style="text-align: center;">Warning</p> <p>Maximum PTO speed for this machine is 1000 rpm.</p>

PTO Shaft Safety

The PTO shaft is a vital link in driving the machine. It is also a very dangerous piece of equipment, therefore it is important to follow the manufacturer's guidelines on maintenance and repair. These guidelines are fixed to the PTO when new. They should be removed, read carefully and then stored with this instruction manual for future reference. If the guidelines are missing from the PTO Shaft please contact your Hi-Spec dealer for another copy.

The irregular shape and connection joints of a turning shaft can cause serious injury. The rotational force of the shaft is the main hazard.

Do not wear loose fitting clothing or articles such as jewellery that might get caught in a turning PTO. The rotation of the PTO is 1000 rpm when spreading. Accidents can happen very fast therefore keep a safe distance from the shaft when it is in use.



PTO Shafts account for most of tractor related fatalities.

**Make sure the shaft is guarded.
Replace the guards when they are
Damaged or missing.
Never use the machine with
Damaged or missing guards
In an emergency situation, take the PTO
Out of gear, stop the engine and set the brake.**



Machine Overview

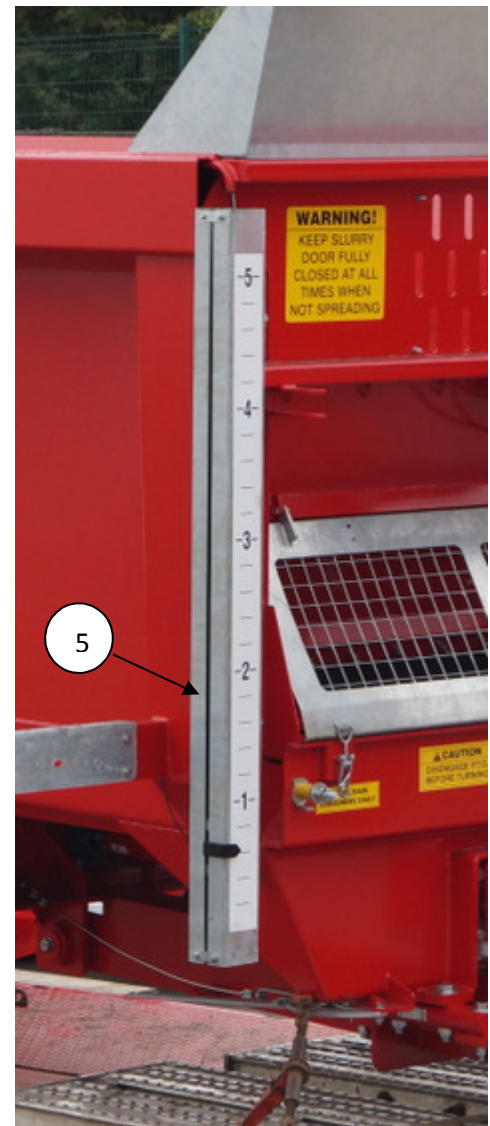
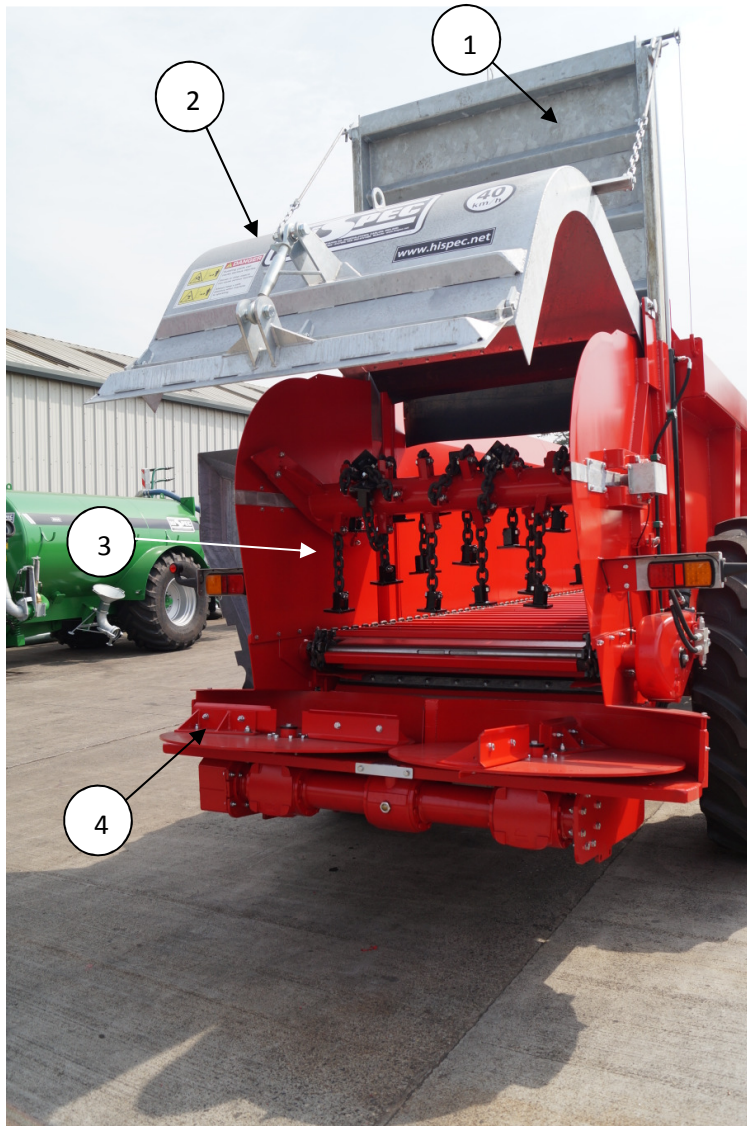

- 1 – Slurry Door
- 2 – Rear Hood
- 3 – Chains and Flails
- 4 – Spreading Spinners
- 5 – Slurry Door Indicator

Getting Started

Tractor Requirements

Horsepower

Minimum 100 + H.P. (75 + kW)

Hydraulic Requirements

For the operation of the Xcel 1250 the tractor requires two double acting spool valves. The hydraulic hoses are colour coded for your convenience and are as follows.

The hydraulic oil flow from the tractor should be set at 100 l/min if adjustment is available.

Slurry Door Operation

Green - Slurry door Up

Blue - Slurry door Down

Floor Chain Operation

Blue - Floor chain Unload

Yellow - Floor chain Reverse

Brakes

Black - Brake line

More details on hydraulic operations are outlined further in "Operating Instructions".

Connecting to Tractor

1. Two double acting valves are required on the tractor.
Valve one operates the slurry door.
Valve two operates the floor chain.
2. Connect brake connection to the tractor.
3. Connect the electric plug (flow control override) to a socket or cigarette lighter on the tractor.
4. Connect tail light plug to the tractor.
5. Adjust the spreader drawbar to ensure that the spreader is level or high to the front when attached to the tractor. Adjustment options are shown in Fig. 1
6. Connect PTO shaft to tractor making sure that shaft guard chains are anchored. Please ensure the PTO is the correct length (As detailed in 'Fitting PTO shaft')

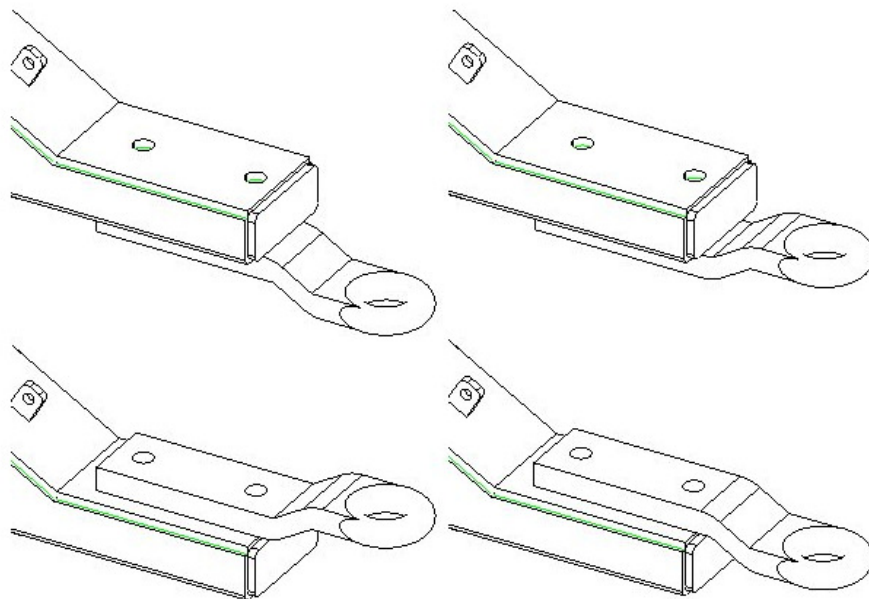

Fig. 1

	<p>The operator MUST be competent in the use of the machine. By competent we mean they have obtained certain knowledge by training and are proficient in using the machine.</p>
	<p>Always keep all hydraulic hoses and electric cables clear from the PTO shaft.</p>



Fitting PTO Shaft

Turn the tractor to full lock to either the left or right to get the shortest point of the PTO shaft.

Slide the PTO apart and fit one half to the tractor and the other end to the machine.

Lift the two parts of the PTO shaft up so that they are level with each other.

Mark 150 mm (6") back from each other as shown in the diagram below.

Cut off the excess profile.

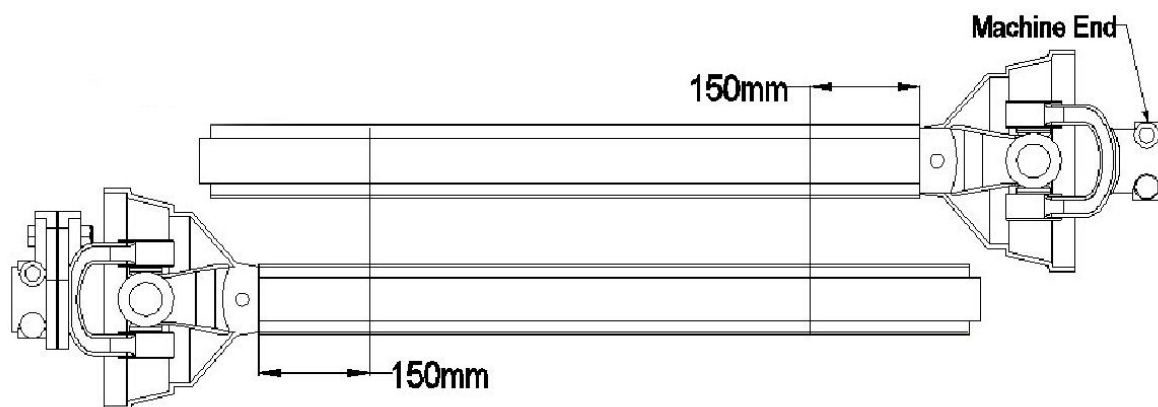

Correct fitting of the PTO shaft is required to prevent damage to the machine or tractor.

Road Transportation

Before bringing your machine onto a public road, it is important to check thoroughly that the machine is following all of the appropriate guidelines.

- Ensure brakes are connected and working correctly
- Ensure lights are connected, in working position and working correctly
- Ensure PTO is disengaged
- Observe local maximum road speeds for this type of machine
- The operator must ensure that any other regulations regarding road use are adhered to.



At over 3m wide the Xcel 1250 Spreader is over the road legal width in some countries. The operator **MUST ensure all local laws are adhered too.**

Emergency Breakaway Handbrake

The emergency breakaway handbrake should be connected to the tractor every time the Side Spreader is been used. It should be done using the wire rope provided. The wire rope should be attached to a solid part of the tractor like the top link pin and not to a panel on the tractor.

The wire rope should be tight enough so it will work effectively if the Side Spreader became detached from the tractor but loose enough that the handbrake is not been applied during normal operation.

Handbrake in the off position

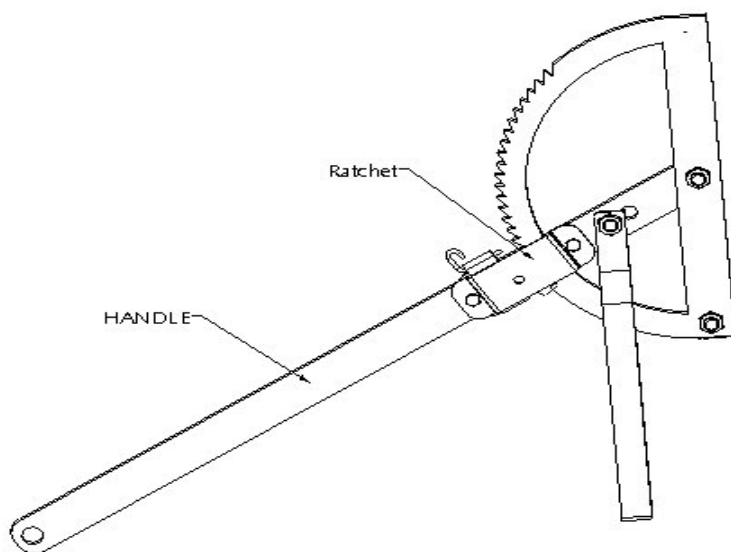

Handbrake in the on position

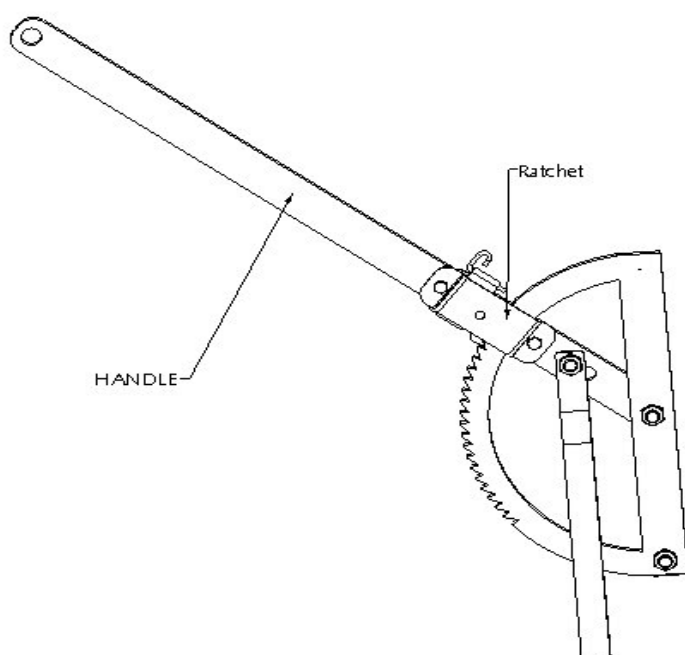

Disengaging the Emergency breakaway handbrake

It is disengaged by following the steps below:



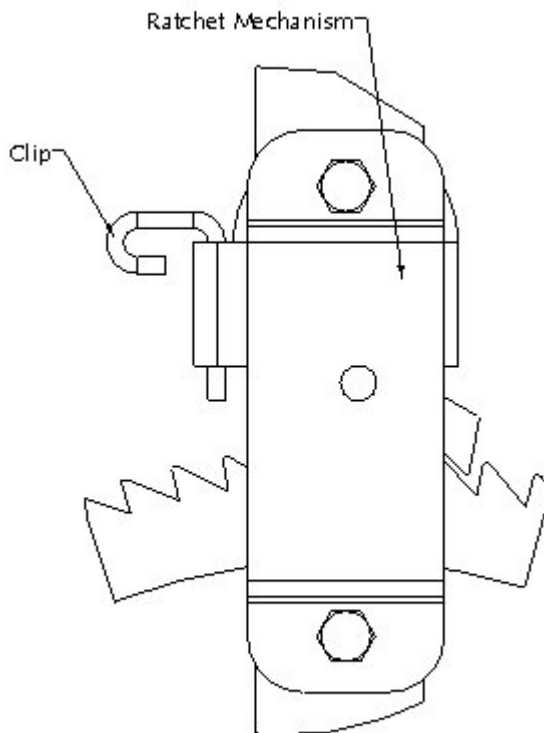

- Make sure the clip in front of the ratchet is facing forward or turned away from the gearbox on the feeder.
- If the clip is turned towards the gearbox the ratchet mechanism will not release.



- Push the handle towards the feeder so the ratchet becomes tight against the teeth that hold it in place.
- Pull the handle away from the feeder so the ratchet will disconnect itself from the teeth.
- Push the handle back to its original off position.

WARNING: It is important to check that the handbrake be fully released when the spreader is in use. If the brake is left half applied it will cause damage to the brakes on the spreader.

Operating Instructions

	Observe all safety instructions!
	Never use the height of the slurry door to control the output of solid material.
	Always switch off PTO before making turns.
	The loaded mass may not be more than the maximum mass indicated on the machine.

Loading Instructions

1. Fold up rubber flap on front panel.
2. When filling the machine with straw based material the load should be 100 mm (4 inches) under the tube in front of the slurry door in the rear half of the machine. The front half can be filled up to the height of the front panel.



When straw based manure is loaded too high the load can get jammed under the slurry door. To remove the choke, reverse the load before returning the floor to spreading direction. Repeat this process if required.

Spreading Instructions

Flow control valve

This valve is positioned on the front of the machine and features a dial. It is used to adjust the floor chain speed. Turning the valve 'clockwise' reduces the floor chain speed and turning the valve 'anticlockwise' will increase the floor chain speed. To adjust the speed use a $\frac{1}{3}$ turn at a time until the desired speed is found.

Flow control override switch

This switch is used to bypass the flow control valve to increase the floor chain speed to the maximum for unloading. This should only be used at the end of a load to empty the machine completely. It is to be positioned in the cab of the tractor and can be plugged into a 2-pin plug or cigarette lighter socket.

Slurry door

The slurry door **MUST** be closed for loading and transport. For spreading solid material it **MUST** be fully opened. For spreading flow-able material the slurry door height can be used to adjust the amount being spread.

Spreading solid material

1. Open slurry door fully.
2. Adjust the flow control valve to the required setting.
3. Switch 'On' flow control override until the material reaches the shredding shaft. Switch 'Off' to begin spreading.
4. The amount spread is controlled by the forward speed of the tractor and the flow control setting.
5. When load is almost empty switch 'On' the flow control override and lower the slurry door to the material height. This prevents material being spread forward over the tractor.

Spreading flow-able material (slurries, sewage pellets etc.)

1. Use the slurry door opening and the forward speed of the tractor to adjust the amount being spread.
2. Set the flow control valve at the lowest setting.
3. When spreading flow-able materials it may be necessary to load some solid material on the front rubber and rear door rubber to ensure the rubbers seal properly.



Always turn off and disconnect flow control override switch when parking overnight.

Special 6 vane spreading discs are available as an option for spreading light materials where no stones are present.

These are used for spreading chicken manure, sewage pellets, etc.

If the material has any stones or hardened lumps, it will damage the vanes on these spreading discs.

Please contact your Hi-Spec sales rep for further details.

Maintenance

	Installing, doing periodical maintenance and performing repairs may only be done by technically skilled person unless otherwise indicated.
	When repairing, maintaining and cleaning always shut down the motor, remove ignition key and carefully observe the instructions in the manual.
	Always use the correct tools and wear gloves when performing any maintenance. If working on a hoisted machine always ensure decent support.
	Damage, including damage caused by insufficient greasing, is not covered by the warranty.
	When servicing gearboxes always ensure that any waste oil is properly disposed off according to the local environmental laws.
	After the first hour operating, tighten wheel nuts and check around machine for any problems.
	If there is a problem with the machine contact your local Hi-Spec Dealer or Hi-Spec Engineering Ltd directly.

Correct Maintenance and Inspection Procedures

- ✎ Learn how to service your machine correctly.
- ✎ Follow the correct maintenance and inspection procedures shown in this manual.
- ✎ Inspect the machine daily before starting.
- ✎ Walk around the machine checking general appearance.
- ✎ Check for loose or missing parts.
- ✎ Always disengage the PTO and stop the tractor engine before greasing and making any adjustments.
- ✎ Never operate the machine without safety guards in position.



During operation, some parts of the hydraulic system can become hot; allow the machine to cool down before beginning inspection or maintenance procedures.

Recommended Maintenance

Every 25 operating hours

- Check and tighten all wheel nuts
- Check and tighten all nuts and bolts. Tighten if necessary. Use torques given.
- Check tightness of all rotor chain bolts.
- Check tire pressures.
- Check all hydraulic hoses and hydraulic cylinders for damage, wear and leakage. Replace any damaged parts.
- Grease all points.
- Check floor chain tension.

Every 50 operating hours

- Check chain oiler reservoir. Top up with grade 10 hydraulic oil.

- Check all other gearbox oil levels.
- Check wear on rear spinners and on the chain flails. Turn or replace if necessary.
- Check rotor chain flail clearance for floor chains, clearance should be 20-25mm. (see page 29 for instructions on shortening chain flails)

Every 6 months

- Check wheel bearings for any slackness. Adjust if required.
- Remove hubcap and fill with grease.

Bolt tightening torques

Bolt tightening Torque (8.8 quality bolts)		
Thread Dimension	Spanner Size (mm)	Tightening Moment (Nm)
M8	13	24
M10	17	48
M12	19	85
M14	22	135
M16	24	210
M18	27	290
M20	30	400
M22	34	550
M24	36	700

Tyre Details

The Xcel 1250 Spreader is fitted with Alliance 580/70 R38 (170A8/167B) tyre and wheel assemblies. Hi-Spec Engineering recommends the use of these tyres only.

Recommended Pressures (Speed 25km/h)

Minimum – 2.4 bar (35 psi)

Maximum – 2.8 bar (41psi)



Wheel removal/refitting

Due to the size and weight of trailing agricultural machines special precautions must be adhered to when removing or replacing a tyre and wheel assembly. It is strongly advised that if a tyre is punctured or damaged any repair work is carried out by a skilled professional tyre fitter.

It is advised that before any work is carried out;

- If the machine is a hazard on a public road that suitable warning is provided to other road users;
- The machine is emptied and moved to a level area with good solid ground;
- The machine wheels are chocked and it is hitched to a tractor with its parking brake effectively engaged;
- A jacking / lifting / supporting position is chosen to maintain maximum machine stability;
- The load at the jacking / lifting point is known;
- The jacking / lifting equipment has sufficient lift capacity and is adequately maintained for the task;
- Ground conditions at the jacking point can withstand the loading;
- The hydraulics of any Forklift Truck / Telescopic Handler / etc, deployed are not solely relied upon while working in the danger zone;
- An adequately rated axle stand or other prop is positioned following the same safety procedure as for choosing the jacking point;
- There is no possibility of slippage between the safety prop (axle stand or other adequate strength support) and the machine;
- As far as possible those involved in the task stay clear of the danger zone (crush area if the machine were to collapse off its temporary support);
- Where possible, mechanical aids are used to lift / position wheels;
- High visibility clothing is worn where appropriate and where possible the work is carried out away from live traffic;
- Please consult your local Hi-Spec dealer or contact Hi-Spec Engineering Ltd directly if there are any queries.

Greasing and Maintenance Points

<i>Point</i>	<i>Description</i>	<i>Grease</i>	<i>Operating Hours</i>
A	Central greasing point	Solid	25
B	Front shaft	Solid	25
C	Main drive shaft	Solid	25
D	Brake splines	Solid	25

This symbol is found on each greasing point on the machine.



Grease Points A



Grease Points B



B

Grease Points C



Grease Points D

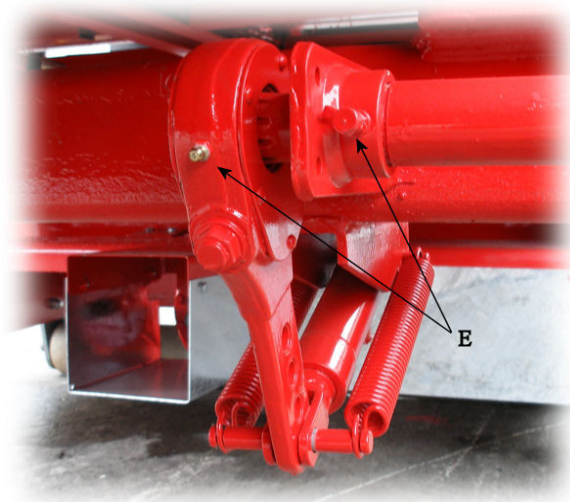

General Repairs

Chain Flail Shortening

The Xcel chain flails can be shortened when they have lengthened due to wear on the links. As shown in Fig.1. Insert a M16 x 50 bolt in the corner of a link and tighten. The bolt should be positioned on the 'back' side of the chain so it will be protected from stones etc. when the machine is operating. The rotor turns clockwise when looking from the left. This will lock the links and shorten the chain by 30mm.



Figure 1

Rotor Main Drive Chain Tensioning

The rotor drive chain tension is adjusted using the threaded adjusting bar on the tensioner arm. Open the lock nut first. Then the outside nut (1) should be tightened until a gap (0.5mm approx.) appears between the coils of the spring (2). Tighten the lock nut.

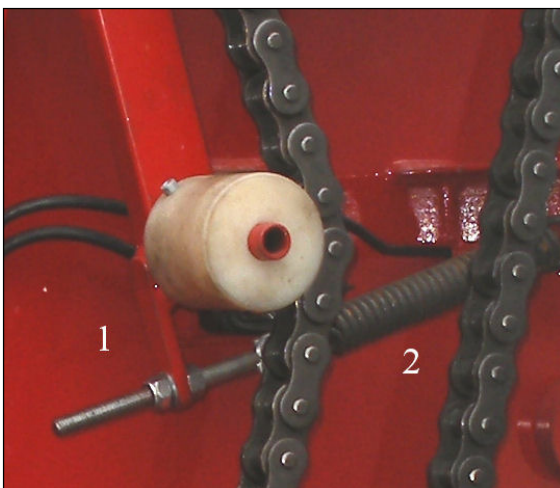

Floor Chain Cross-Slat Replacement

- Rotate floor until slats to be replaced are positioned in the centre of the machine floor. (1)



- Turn off tractor and remove all hydraulic and PTO connections to the machine.
- Slacken the floor chains by loosening the tensioners (2) at the front of the machine and also opening one hydraulic hose off of any of the tensioning rams under the front of the machine.

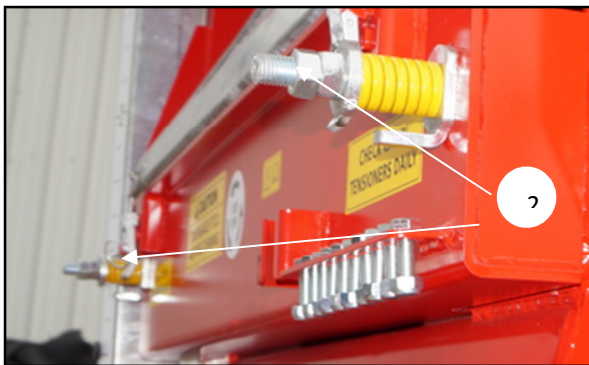

- It will now be possible to remove the cross slats by raising the chain and sliding the holding cleat from the cross slat.
- To re-tension the chain, reconnect the hydraulics, open the slurry door, then lower the door allowing the system to pressurise at the end of the down stroke. The tensioning rams are pressurised by the slurry door down function.
- Tighten the front manual tensioners back to the front cover. They should only be tightened to the cover and NO extra tightness applied as the chain tension is set by the hydraulic tensioning rams.

Floor Chain Tensioning

- Use the bolts at the front of the machine to tension the floor chain (2).
- Floor chains are tensioned correctly when it is difficult to raise the floor chain off the centre of the floor by hand, but you should be able to raise it by approx. 10mm.

Chain Flail Head Replacement

- Open holding bolt (1)
- Remove head (2)
- Fit replacement head and bolt and tighten

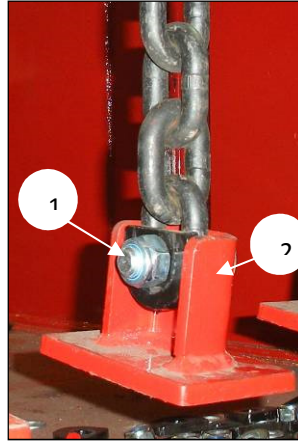

Replacing Rear Hardox Vanes

- Remove bolts (1) and worn plates (2)
- Fit replacement new plates
- Check that the clearance under the plates are ok for full rotation.

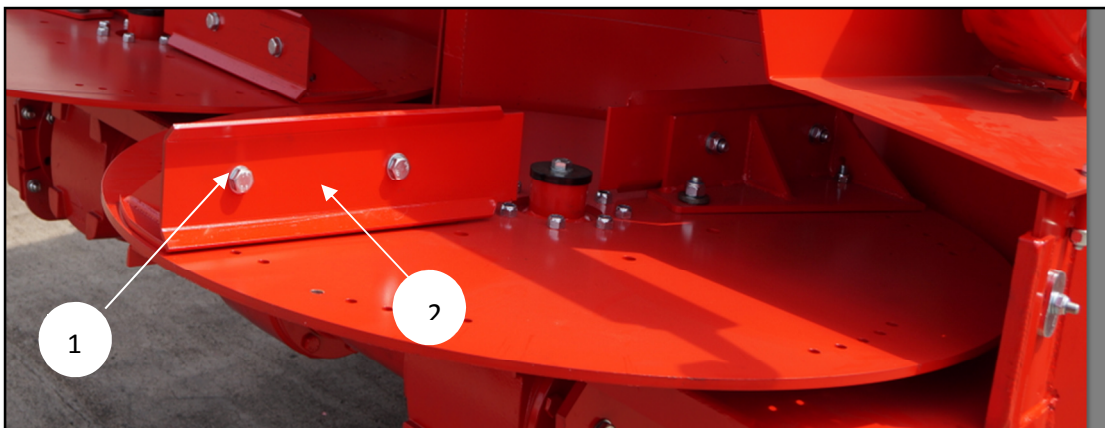

Replacing Spreading Discs

- Open bolt in centre of standard disc (1)
- Lift discs evenly to slide off centre spline (2)
- Grease spline
- Position new disc over spline and slide into place
- Check that the clearance under the plates are ok for full rotation.
- Use washers supplied to fill any height gap between the top of the disc and the top of the gearbox spline
- Fit top cap and tighten centre bolt

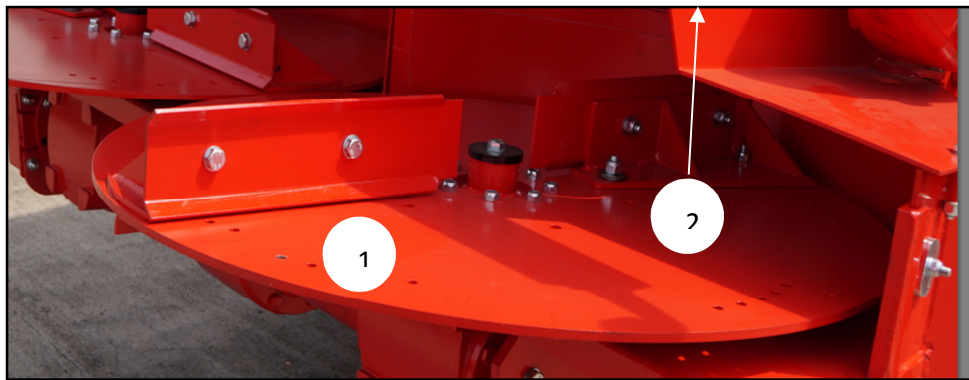

Sales and Service

Ireland

Head office

Hi-Spec Engineering Ltd., Station Rd, Bagenalstown, Co. Carlow, Ireland

Tel: - +353 59 9721929 Fax: - +353 59 9721980

Email: - sales@hispec.net or info@hispec.net

After Sales Service

Contact: - Eoin Keane, Hi-Spec Engineering Ltd. Tel: - +353 87 2562963

Email: - eoin@hispec.net

Machine Servicing

Contact: - Michael Brennan, Hi-Spec Engineering Ltd. Tel: - +353 87 2403312

Spare Parts Store

Contact: Mike Nolan or Terence Byrne, Hi-Spec Engineering Ltd.

Tel: - +353 59 9721929 Fax: - +353 59 9721980

Email: - stores@hispec.net

U.K.

After Sales service:

Southern England & Wales

Contact: - Edward Lewis, Hi-Spec Engineering Ltd. Tel: - +44 7876 452698

Email: - elewis@hispec.net

Northern England & Scotland

Contact: - Gordon Brodie, Hi-Spec Engineering Ltd. Tel: - +44 7799 905130

Email: - gordon@hispec.net

For spare parts

Contact: - Your local Hi-Spec dealer. If you require a contact name and number you can telephone head office and we would be glad to assist you.

Warranty

The following is a list of warranty terms. Warranty claims will be disallowed if they do not fall into the categories shown here.

Warranty Terms

Subject to condition of sale

6 months on all parts, excluding the below;

NO Warranty on the following:

- PTO Shafts
- Hydraulic fittings
- Hydraulic hoses
- * Electrical connections between machine and tractor

NO Warranty allowed for breakdowns due to:

- Misuse of the machine, e.g. overloading by the operator
- Lack of maintenance, e.g. failure to carry out regular oiling and greasing of components and bearings where appropriate

Conditions of Sale

General

In these conditions the word "Company" means Hi-Spec Engineering Limited. The word "dealer" means a customer of Hi-Spec Engineering Ltd. Purchasing machines from them for resale at recommended retail prices and the word "first user" means the first person to whom the dealer sells any goods for actual use. The company's employees may negotiate orders and issue quotations but an order is only binding on a company when it has acknowledged the order in writing on the company's official acknowledgement forms.

Such acknowledgement and confirmation will only be given subject to these conditions of sale. The acceptance of delivery of the goods either at the dealer's premises or those of the first user if delivered direct to the first user shall bind the dealer and the dealer shall only sell to the first user on conditions which incorporate the company's warranty. If he fails to sell the dealer shall have no claim whatsoever against the company except insofar as the company will honour the warranty to the dealer and through him to the first user. The term goods where used means such articles as are invoiced by the company whether manufactured, imported, distributed or otherwise sold by them.

Delivery

Should the company be prevented from delivering any goods owing to any lockout, strike, weather conditions, or other exceptional causes occurring either at their own premises, or elsewhere, then delivery shall be postponed until a reasonable time after the occurrence has ceased to cause delay, unless the parties shall mutually agree to the cancellation of the contract in respect of such goods.

Cancellation of Orders

The only ground for acceptance of a cancellation of an order shall be the non acceptance of these terms and conditions by the dealer and then only if

Within seven days of receiving notification of the terms and conditions the dealer notifies the company in writing of its non-acceptance.

The dealer pays the company any losses suffered including any carriage charges if these have been incurred.

Delays

While every effort has been made to adhere to delivery dates or times quoted by the company, such dates or times given though given in good faith are mere estimates only. The company accepts no responsibility for delay in delivery or for the consequences of such delay however caused nor shall the dealer be entitled to reject goods thereof by reason.

Design

No responsibility is accepted for any deviation from drawings or from illustrations in catalogues, price lists, brochures or advertising material for discrepancies in weight, rated outputs. Performance from those mentioned here in which shall be treated as illustrative and approximate only.

Price

Any fluctuation in prices arising after the contract but before dispatch shall entail adjustment in the contract price and the price to be paid shall be fixed at the date of dispatch.

Damage, Shortage or Loss

The company do not accept any responsibility for any damage, shortage or loss in transit when goods are dispatched to instructions and where the transit is affected through a third party and not by the Company itself.

Conditions of Resale

The dealer shall only re-sell any of the company's products with the full and unaltered warranty that is issued with every machine invoiced by the company. If the dealer either through negligence or for any other cause fails to get the agreement of the first user to accept this warranty the dealer shall have no other recourse against the company except that contained in these conditions of sale and he dealer expressly agrees that in accepting delivery he has recourse in law against the company nor will he join the company as third or other party in any action which results against him from the resale of the company's products.

Warranty

The Company warrants its products through the dealer and through the dealer to the first user. The dealer shall only re-sell the company's machines with the benefit of the company's warrants. The said warranty is as follows:

The company warrants, subject as hereinafter provided, that all new goods supplied by it shall be free from defects in material and workmanship, its liability under such warranty being limited to making good at a factory to be nominated by it, such parts or parts which shall within six calendar months from the date which the product was delivered new to the retail purchaser be returned to the company or its authorised representative which the company is satisfied on its examination of the part or parts to have been defective in material or workmanship provided that. All replaced parts shall become the property of the company.

The foregoing warranty does not extend to any product which shall have been repaired, altered, neglected or used in any way so as, in the judgement of the company (whose decision is final) may have adversely affected its stability or reliability, nor does this warranty apply to proprietary articles, accessories or parts not manufactured by the company but where any such warranty is given by the manufacturers of such articles, accessories or parts any benefits under such warranty will be passed on by the company.

The company will not be responsible for damage or loss caused by incorrect machine settings, ground speed or operation of the machine in unsuitable conditions and the company's decision as to the suitability of the condition shall be final. Fair wear and tear is excluded from any claim and no responsibility whatsoever is accepted for damage, which in the company's Opinion is caused by hazards of soil, stones or foreign objects.

The warranty is transferable to a second or subsequent owner (within the warranty period) subject to the company being notified in writing of this change of ownership.

Complaints referring to faulty or incomplete deliveries or to obvious faults must be notified to the dealer in writing within fourteen days after receipt of goods. In the absence of such notification delivery shall be considered as having been accepted as in good order and condition.

The company does not give any warranty in respect of its goods except therefore going Warranty which is given expressly in lieu of and excludes all other warranties and conditions expressed or implied whether under common law, Statute or otherwise and every form of liability for loss or damage direct or consequential or for any accidents resulting from defective material faulty workmanship or otherwise, is expressly excluded.

Liability

In no circumstances whatsoever shall the Company's liability (in contract, tort or otherwise) to a buyer under, out of or in connection with this contract or the goods supplied exceed the invoice price of the particular goods in regard to which component is made.

Title of the Goods

The title in the goods shall not pass to the customer until the customer shall have discharged all sums due by the customer to the company at the date of the final handing over of the possessions of goods

Interest

If the customer shall fail to pay any sum due in foot of this transaction within fourteen days after the same shall become due, the customer shall pay interest thereon calculated from the due date of payment at the annual rate equal to 4% over the prime rate charged from time to time by the associated banks on secured loans to individual customers.

Registration Forms



Hi-Spec Engineering Ltd.
Station Rd., Bagenalstown,
Co. Carlow, Ireland
Tel: - 059 9721929
Fax: - 059 9721980

Please complete the following forms in full.

The first is a warranty registration form; this form is issued in accordance with our conditions of sale and with particular reference to the condition governing warranty. We cannot process a claim unless all particulars are supplied.

The second is an acceptance form, which the purchaser is asked to sign to acknowledge he/she has received a copy of the Operator manual and full training for the machine purchased.

Please do not sign if you have not received both of these.

Warranty Registration

Date of Purchase: _____
Purchaser's Name: _____
Signature: _____
Address: _____
Phone: _____
Dealer's Name: _____
Signature: _____
Address: _____
Phone: _____
Machine Type: _____
Machine Model: _____
Serial Number: _____

Training & Operator Manual Registration

Please sign the following declaration to state that on the day you (the purchaser) purchased a Hi-Spec XCEL 1250 you received operator manual and training instructions.

I, the purchaser have received my Hi-Spec XCEL 1250 Operator Manual and training from the below dealer

Purchaser: _____ Signature: _____
Date: _____
Dealer: _____ Signature: _____
Date: _____

This copy is to be kept in your manual for your reference.





Registration Forms



Hi-Spec Engineering Ltd.
Station Rd., Bagenalstown,
Co. Carlow, Ireland
Tel: - 059 9721929
Fax: - 059 9721980

Please complete the following forms in full.

The first is a warranty registration form; this form is issued in accordance with our conditions of sale and with particular reference to the condition governing warranty. We cannot process a claim unless all particulars are supplied.

The second is an acceptance form, which the purchaser is asked to sign to acknowledge he/she has received a copy of the Operator manual and full training for the machine purchased.

Please do not sign if you have not received both of these.

Warranty Registration

Date of Purchase: _____
Purchaser's Name: _____
Signature: _____
Address: _____
Phone: _____
Dealer's Name: _____
Signature: _____
Address: _____
Phone: _____
Machine Type: _____
Machine Model: _____
Serial Number: _____

Training & Operator Manual Registration

Please sign the following declaration to state that on the day you (the purchaser) purchased a Hi-Spec XCEL 1250 you received operator manual and training instructions.

I, the purchaser have received my Hi-Spec XCEL 1250 Operator Manual and training from the below dealer

Purchaser: _____	Signature: _____
Date: _____	
Dealer: _____	Signature: _____
Date: _____	

This copy is to be posted to Hi-Spec Engineering or given to your dealer



Declaration of Conformity

EC Machinery Directive

2006/42/EC

We hereby certify that the machinery stipulated below complies with all relevant provisions of the EC Machinery Directive.

Modifications to the machine without prior approval from the undersigned will render this declaration null and void.

Machine Description and Function:	Manure Spreader designed for use of transporting and spreading agricultural manure
Make:	Hi-Spec
Model:	XCEL 1250
Serial Number:	
Manufacturer:	Hi-Spec Engineering Ltd.
Address:	Station Rd, Bagenalstown, Co. Carlow, Ireland

Technical file compiled by: Derek Whelan, Myshall, Co. Carlow

Harmonised standards applied:

EN ISO 12100-1:2003, Safety of machinery Part 1: Basic terminology, methodology

EN ISO 12100-2:2003, Safety of machinery Part 2: Technical principles

EN ISO 4254-1:2005, Agricultural machinery -- Safety -- Part 1: General requirements

BS EN 690:1995, Agricultural machinery, Manure spreaders, Safety

Signed: _____

Date: **28th November 2014**

Name: **Mike Nolan**

Position: **Managing Director**

Being the responsible person appointed by the manufacturer.

Hi-Spec Engineering reserve the right to make changes and improvements at any time without incurring any obligation to make such changes on products previously sold.

